

The Islamic University of Gaza

Deanery of Higher Studies

Faculty of Education

Community Mental Health/Rehabilitation Science Master Program



**Standing Training with Manual Body Weight Support to
Improve Standing in Nonambulant Children with Spastic
Diplegic Cerebral Palsy in the Gaza Strip**

Prepared by:

Rana Habib Imad

Supervised by:

Dr. Jean E. Calder, AC

Dr. Khamis El-Issy

***A Thesis Submitted in Partial Fulfillment of Requirement for the Degree of Master
of Rehabilitation Science***

2011/ 1432

Abstract

The aim of the study was to identify improvement in standing ability in children with spastic diplegia Cerebral Palsy who are nonambulant after 21 weeks of standing training with manual BWS intervention conjunct with regular stretching exercises.

Design: Setting: home based rehabilitation.

Design: pre and post experimental design.

Subject: 15 children of moderate to severe spastic diplegic cerebral palsy children aged from 4-8 years old at level III-IV of gross motor function classification system were selected randomly according to specific criteria to participate in the program.

Intervention: participants underwent standing training with manual body weight support twice a week for 18 weeks over a period of 21 weeks.

Main measures of progress during training: the gross motor function measure-88 was used to assess the performance of all children sample in dimensions A, B, C, and D twice immediately before and after training.

Result: there was a highly significant differences in the dimension A, B, C, and D of the gross motor function measure-88 scores of children by a mean difference of 5.3% in total goal of gross motor function and 4.42% in standing dimension after 18 weeks of standing training with body weight support regarding to gross motor function measure-88. Fourteen out fifteen children demonstrate improvement in their standing ability after 18 weeks of standing training with body weight support.

Conclusion: standing training with manual partial body weight support improved standing ability in addition to filling gaps in gross motor functions that preceded standing in 15 nonambulant children with spastic diplegic cerebral palsy who could not support own weight on their legs and underlying the need for intensive application of STBWS.

برنامج تدريبي على الوقوف مع إعطاء مساعدة يدوية من قبل المعالج لتحسين مقدرة الوقوف لدى الأطفال المصابين بالشلل الدماغي التيبسي (الأطراف السفلية) الغير قادرين على الوقوف داخل قطاع غزة

ملخص الدراسة

الهدف من الدراسة: تهدف هذه الدراسة إلى تحسين مقدرة الوقوف للأطفال الشلل الدماغي الغير قادرين على الوقوف من خلال استخدام برنامج التدريب على الوقوف مع إعطاء مساعدة يدوية من قبل المعالج لتخفيف جزء من وزن الطفل المحمل على قدميه لإتاحة أكبر ممارسة ممكنة من الطفل لأداء وظيفة الوقوف بمساعدة ومن ثم تقليل كمية المساعدة تدريجيا مع تحسن قدرة الطفل.

الطريقة البحثية المستخدمة: اختبار ما قبل و بعد تطبيق التدريب العلاجي.

مكان تطبيق البحث: طبق البحث داخل منازل الأطفال.

العينة: عينة البحث مكونة من خمسة عشر طفل وطفلة تم اختيارهم عشوائيا من داخل قطاع غزة ذو قدرات عقلية جيدة، تتراوح أعمارهم من أربعة إلى ثمانية سنوات، تشخيصهم الطبي هو: شلل دماغي من نوع شد، رباعي مركز على الأطراف السفلية، يتدرج في حدته من متوسط إلى شديد.

مجريات البحث: أجريت الدراسة لمدة ثمانية عشر أسبوعا علاجيا بمعدل جلستين في الأسبوع خلال فترة زمنية قدرها إحدى وعشرون أسبوعا باستخدام برنامج التدريب العلاجي على الوقوف بمساعدة، واستخدم لقياس النتائج أداة قياس عالمية تسمى "مقياس الوظائف الحركية الإجمالية" وطبق المقياس قبل التدريب العلاجي وبعد الانتهاء منه مباشرة.

النتيجة: أظهرت النتائج البحثية بعد تحليلها تطور ملحوظ ذو فروقات ذات دلالة إحصائية في قدرات أطفال الدراسة المطبق عليهم البرنامج العلاجي في بنود المقياس الآتية: الزحف والجلوس والحبو والوقوف.

الخاتمة: يعد البرنامج العلاجي " برنامج التدريب على الوقوف بمساعدة لأطفال الشلل الدماغي " ذو أهمية كبيرة ويؤدي إلى تحسن قدرات الأطفال الحركية وبناء وظيفة الوقوف لدى أطفال الشلل الدماغي الغير قادرين على الوقوف وبالتالي نوصى بضرورة تطبيقه داخل المؤسسات العلاجية الراحية لأطفال الشلل الدماغي.

Dedication

This thesis is dedicated to all who have encouraged and supported me throughout my academic endeavors from kindergarten through master.

Acknowledgements

I would like to thank the children and their parents who participated in this study. Thanks for my family especially my youngest sister Fidaa for supporting me during my study. Thanks for Dr. Mohammed Nasser in El-Azhar University who helped me to handle the manual book of GMFM. Thanks for Abuhammad factory as helped me in making the jacket design for a measurement tool. Thanks for El-Shifa hospital, its physiotherapy team, and special thanks for its biomedical engineering for helping me in measurement of children at El-Shifa Hospital. Thanks for these rehabilitation institutions: Palestinian Medical Relief Society, Society of Physically Handicapped People, The National Society for Rehabilitation, Palestinian Avenir for Childhood Foundation-Cerebral Palsy Center in Gaza strip for their assistance with sample collection.

Table of Contents

Abstract	I.
Dedication	V.
Acknowledgements	V.
Table of Contents	VI.
List of Tables	VIII.
List of Figures	IX.
List of Abbreviation	X.
Chapter 1 Introduction	1.
Chapter 2 Study Framework.....	14.
Literature Review	32.
Chapter 3 Methodology	47.
Chapter 4 Results	59.
Chapter 5 Discussion	71.
References	83.
Appendix 1 ethical approval for research	92.
Appendix 2 list of children participated in the study	95.
Appendix 3 parental permission to participate in research	96.
Appendix 4 gross motor function measure (GMFM) score sheet (GMFM-88 and GMFM-66 scoring)	99.

Appendix 5 gross motor function classification system and prediction outcomes ..	105.
Appendix 6 Ashworth scale	106.
Appendix 7 observation of improvements of motor abilities during 21 weeks of STBWS program for each child	107.
Appendix 8 distribution of the study sample according to area	109.

List of Tables

Table 1. clinical characteristics of participants	48.
Table 2. training session summaries	57.
Table 3. the group means and SD for the dimension A, B, C, D of Gross Motor Function Measure for subjects at two measurement times	59.
Table 4. list of children participated in the study.....	95.
Table 5. expected functional abilities for children aged 6 to 12 years, according to the Gross Motor Function Classification System (GMFCS)	105.
Table 6. observation of improvements of motor performance of function during 21 weeks of STBWS program for each child.....	107.

List of Figures

Figure 1. normal motor development milestones	16.
Figure 2. stages in development of standing	20, 21, 22.
Figure 3. examples of upright standers	25.
Figure 4. cerebral palsy child equipped with a simple easy walk machine with a harness at El-Shifa hospital in Gaza	51.
Figure 5. cerebral palsy children undergoing STBWS therapy at their homes	54.
Figure 6. examples of stretching of different joint have used in STBWS program ..	56.
Figure 7. mean change in the dimension A, B, C, D, and total goal score of GMFM-88 scores for children following participation in the program of STBWS.....	60.
Figure 8. mean score of standing dimension of GMFM-88 for children between initial and final assessments.....	61.
Figure 9. percentage of mean change in total changes of the dimension A, B, C, D, and total goal score of GMFM-88 scores for children after the effect treatment of STBWS	62.
Figure 10. show a child became able to stand with arms free for seven seconds	69.
Figure 11. prediction of outcomes	108.
Figure 12. distribution of the study sample according to area.....	109.

List of Abbreviation

- ADL: activities of daily living.
- AS: Ashworth scales.
- BWS: body weight support.
- BWST: body weight support training.
- BWSTT: body weight support treadmill training.
- CE: conductive education.
- CIT: constraint-induced movement therapy.
- CP: cerebral palsy.
- CNS: central nervous system.
- EDL: pediatric evaluation of disability inventory.
- GMFCS: gross motor function classification system.
- GMFM: gross motor function measure.
- Kg: kilograms.
- NDT: neurodevelopmental treatment.
- PBWS: partial body weight support.
- PBWSTT: partial body weight supported treadmill training.
- PT: physical therapy.
- ROM: range of motion.
- SD: standard deviation.
- SPSS: statistical package for the social sciences.
- STBWS: standing training with body weight support.
- TBWS: treadmill with body weight support.

Chapter 1

Introduction

Turmusani (2003) reported that the philosophy of equal rights is illustrated by a number of verses from the Qur'an as follows:

‘O mankind! We created you from a single (pair) of a male and a female, and made you into nations and tribes, that ye may know each other (not that ye may despise each other). Verily the most honoured of you in the sight of Allah is (he who is) the most righteous of you. And Allah has full knowledge and is well-acquainted (with all things) (Ali, 1994) '.

It can be seen from this statement that all people are the same as human being, and have equal rights and dignity, regardless of their age, sex, origin, color, or health status (Turmusani, 2003).

The proportion of persons with disabilities in the Palestinian territories is amongst the highest in the world, with up to about 3.5% of the total population, rising in the provinces of Gaza, in particular. According to the Palestinian Medical Relief Society report in 2008, the number of persons with disabilities in the governorates of the Gaza Strip is more than 70 thousand, and the percentage of disability rate is 4.5 percent (PMRS, 2008).

In spite of current efforts of the Palestinian government, there is no central planning authority with a concept of rehabilitation and an approach to disability. The interest in disability is created by the political situation with its changes in attitude but with more attention being given to the old attitude. There is an urgent need for persons with disabilities to be included in the planning process for inclusion in the

community and family and for adequate and appropriate rehabilitation services to be available for them. There is a lack of adequate skills to deal with severe and multiple disabilities and inadequate qualification of educational staff working with persons disabilities. There is limited availability of quality physically rehabilitation services although all rehabilitation services should be available to the local community where the person with disability lives.

Cerebral palsy (CP) is a motor disorder appearing before the age of three years due to non progressive damage to the brain. Faulty development or damage to the motor area disrupts the brain ability to adequately control movement and posture. “Cerebral” refer to the brain and “palsy” to the muscle weakness/poor control (Chesed, 2003), (MAS, 2005). The incidence of cerebral palsy is approximately 2 cases per 1,000 births in Gaza strip (US Census Bureau, 2004). According to Latash (2008), the male-to-female ratio is 1.5 to 1 (reviewed in Reddihough and Collins 2003). CP may result in abnormalities in motor, alterations in sensation, vision, and speech; and social and emotional problems (Day, 2004).

CP is a heterogeneous condition. Patients with CP diplegia (loss of movement and sensation in corresponding limbs or both sides of the body) account 44% of those with CP, and usually walk with aids (MAS, 2005). In spastic diplegia, the spasticity involves the legs more than the arms, and often an arm may be near-normal (Baird, 1983). Spasticity is defined as velocity-dependent increase in muscle tone to passive stretch (Shumway-Cook, 2007).

Children with spastic diplegia are facing challenging problems of spasticity. Spasticity prevents muscles and tendons from growing at the same rate as lengthening bones. Also, spasticity forms contractures, makes ambulation and fine- or gross-motor

movements difficult, and causes muscle ache. Spasticity in hip adductors leads the hip to adduct and cross when the child has been supported in a standing position (Kyllerman, 1982), (Gage, 1991). One of the method used for measuring the resistance of spastic quantify muscle tone is Ashworth Scale (AS).

Most children with spastic diplegia walk, although late walking is the rule, and it is not unusual for a diplegic child not to begin ambulation until the age of 4 years or even later. Motor improvement often reaches a plateau at approximately the age of 7 years, so if a child is not walking by that stage, there is little likelihood that he or she will walk (Lovell, 2001). So standing retention is the major problem in these children after this age who are nonambulant.

The technique used in this study is standing training with body weight support (STBWS) which was administered over a period of 21 weeks to improve standing ability in children with spastic diplegia who are nonambulant. During this period all the children participated in STBWS conjunct with regular stretching exercise. This training approach is a type of task specific approach which is used in management of CP children.

Kalverboer et al (1993) notes that the efficacy of intervention approaches being used by therapists in training children with CP. It is recognized that children with CP show similar development patterns to that of normal children although at a slower rate.

Standing and walking are fundamental movement patterns that are important motor function abilities. The attainment of these abilities is a common functional goal for children with CP (Day, 2004). In order for children with CP to experience success in the development of standing, the intervention programs need to include specific

training in standing position using appropriate support (Levitt, 2004). Such an approach is in keeping with modern concepts of motor learning and active therapies that advocate using an intensive task specific repetitive approach including body weight support (BWS) (Carr, 1998).

In a review of selected physical therapy intervention programs for school age children with disabilities attending schools in the USA, Effgen and McEwan Effgen (2007) identified the following:

- (a) adapted seating for children with CP; (b) conductive education [CE];(c) constraint-induced movement therapy [CIT]; (d) lower extremity casting, orthoses, and splints for children with neurological disorders; (e) neurodevelopmental treatment [NDT]; (f) partial body weight supported treadmill training [PBWSTT]; (g) passive stretching to improve range of motion [ROM]; (h) strengthening for children with CP; and (i) weight bearing interventions for children with CP (p. 10).

Traditional physical therapy used for children with CP in the Gaza Strip tends to focus on improving muscle strength, local muscular endurance, and overall joint range of motion, but do not target to control standing and walking patterns of children with CP. In general, programs include progressive resistance exercises to improve muscular strength, repetitive passive range of motion (ROM) exercises to improve and maintain joint mobility. Passive, static gentle stretching exercises are given the children on individual joints.

A study was carried out by Ghanem (2008) in order to evaluate the effectiveness of community based rehabilitation services provided children with CP in the Gaza Governorate. The study showed that there was no difference in the responses

of the samples in the item 'stand up from sitting position' for children before and after their program.

Specific attention to the training of standing does not seem to be given adequate attention in the intervention programs being used by physiotherapists working with nonstanding children with CP in the Gaza Strip. More attention seems to be given to training of walking than to that of standing and pre-standing abilities.

Studies conducted on the improvement of walking abilities following training using a treadmill and with support being given by use of a harness (Day, 2004), (Schindl, 2000), (Cherng, 2007). The focus of these studies has been on walking only and have used sophisticated equipment not easily available to physiotherapists in the Gaza Strip. Although not with reference to children with CP, Fulk (2005) has indicated that such training can also occur on the ground.

Melillo and Leisman (2004) have noted that the key of treatment of standing is a gradual decrease of the BWS with time to and as a result of gradual increase of active weight bearing.

Standing and Walking Problems and Prognosis in CP Diplegia

Bobath (1980) reported that

standing and walking in spastic diplegia, which are acquired

late and are only possible if arms and hands can be used for

holding on and support, diplegic children will make excessive

use of whatever righting and equilibrium reactions are present

'above the waist'. They therefore use excessive

compensatory movements of head other trunk and arms as the legs and heads are too stiff to take a step. They cannot shift their body weight automatically onto the standing leg in order to leave the other leg free to make a step. The body weight remains on the inside of the foot. Balance and rotation and seems to 'fall' from one leg to the other in walking; they are unable to stand without holding onto something (p. 53).

'Most diplegic children stand and walk on tiptoe as dorsiflexion of the feet at the ankle would produce an increase of flexor tone throughout their lower limbs, making standing and walking impossible and possibly causing them to collapse' (Bobath, 1980, p. 53).

Center Nervous System (CNS) and task-specific (standing) training as a basis for Rehabilitation

Selzer (2006) reported that 'basis of basic science researcher in animal and human models indicated that central nervous system is malleable and capable of learning and adaptation, even after an injury' (p. 91). This can be promoted by therapy services that are task-specific and provide intense rehabilitation (TIRR, 2005). According to Selzer (2006) task-specific training focuses on improving the performance of functional tasks through repetition and goal-oriented practice.

Motor learning investigators have demonstrated the importance of task-specific training for optimal skill acquisition. If a person is to learn to stand, then

practice in standing is necessary; if walking is the goal, then the person must practice walking (Levitt, 2004). According to specify of learning hypothesis, optimal motor learning occurs when performance during practice is well matched to that required for stimulation and growing of the brain cells. The specify of learning hypothesis is consistent with frequent impulses that stimulate cells, for longest period of time and greatest degree of intensity, which have shown that task-specific activity result in the CNS. The stimulated function then matures more rapidly through use, but this use stimulated development of the area of the brain that controls it (Melillo, 2004).

According to Milillo and Leisman (2004) the prime mover of evolution before the growth spurt of the brain was the ability to stand upright, standing described by Kralj and Bajd (1989) as 'an upright position of human body, or the state of maintaining an upright extended position of trunk and lower extremities' (p. 56). Connolly (1997) reported that standing position provides integration of motor information and sensory information. Researcher suggests that ability to relate sensory input to motor output forms that basis of postural control development.

The unique environment of an upright standing position provides information from the skin on the soles of the feet of particular importance to upright posture. Additionally, neural signals concerning shearing forces of the skin elicited a reflex movement of the foot toward the stimulants, and this increase tone in the extensor muscle of the limb and pelvis as well as supply data on body motion to the CNS (Carreiro, 2003). Furthermore, it enhances the ability to transduce musculoskeletal and gravitational forces. Milillo and Leisman concentrate that the only constant source of stimulation from environment is gravity because we are perpetually forced to resist it by using muscle and joint continuously, the amount of time it stimulates

our brain based on frequency and duration is much greater than that of any other stimulus (Melillo, 2004)

According to Fedrizzi (1994), that important rate timing factors in the emergence of independent standing and walking may be the acquisition of adequate muscle strength to support the body's weight. Therefore, Brill and Breniere concluded that lack of nervous system maturity or experience cause lack of postural responses as well as an inability to support the child's weight during stance, thus what seen in the 8 month old child. In addition, the child with under 200 days of walking experience has not sufficiently mastered the initial posture nor the anticipatory movements required in taking a step, to allow these movements to be integral part of the locomotor program (Kalverboer, 1993).

Body Weight Supported Standing Training

Partial body weight support (PBWS) during locomotor training is a task-specific rehabilitation approach which has been used as a part of a postural management in children with CP, which achieves independent standing in some children with CP, who can then focus on developing skills of walking.

Locomotor training studies on CP conducted only on the progress of development of walking following training have looked on training using a treadmill and with support being given by use of a harness (Day, 2004), (Schindl, 2000), (Cherng, 2007). During this training, the person's body weight is partially supported by an overhead harness to support a certain percentage of client weight while they perform standing and stepping activities (TIRR, 2005).

Body weight support training (BWST) and a treadmill allows a client to maintain a standing position, even if they do not have enough strength or balance to do so independently, without support clients may be limited to very few steps with abnormal gait patterns due to weakness and fatigue (TIRR, 2005). Additionally, it provides a permissive condition that allows the client to experience the characteristic of rhythmic ambulation as well as the specific sensory inputs, such as, correct timing, hip/knee extension, limb loading, and proper trunk posture to promote stepping response (Day, 2004). Moreover, it affords the client an opportunity to practice stepping with speed and repetition necessary to maximize motor learning and plasticity (TIRR, 2005).

Locomotor training is a comprehensive therapy program that addresses all the components of walking include standing, balance, reciprocal stepping, strength, endurance, and motor control (TIRR, 2005). The theoretical basis for locomotion training with PBWS is well established by gradual decrease of the BWS and the level of support with time to and as a result of gradual increase of active weight bearing (Melillo, 2004), (Barbeau, 2003).

Locomotor training with PBWS on previous studies conducted on children with CP has been focused on walking only and has used sophisticated equipment. Although not with reference to children with CP, such training can also occur on the ground using manual assistance (Fulk, 2005). During this training approach which uses the manual assistance of the trainer, Field-Fote (2005) reported that this approach has the advantage that the experienced trainer is able to perceive the level of assistance that is needed as support is reduced.

Gross Motor Function Measure as a measurement tool

Gross motor function changes were measured with the Gross Motor Function Measure (GMFM). The GMFM is a criterion-referenced evaluation tool designed specifically for children with CP. The GMFM is composed of 88 test items, categorized into five developmental dimensions A (lie/roll), B (sit), C (crawl/ kneel), D (stand), and E (walk/run/jump). Each item scores for each dimension is summed together and converted, yielding a percentage score for that dimension. Results of studies have provided support for the high internal reliability and construct validity of measurement of changes in motor function (Cherng, 2007). GMFM is the most frequently used instrument for assessment of efficiency of the physical therapy and other treatments of CP (Staheli, 2003). Therefore, GMFM was chosen as the outcome measure assessment tool for this conducted study.

Gap

The only experimental studies of clients with CP, however, have been carried out using body weight support treadmill training (BWSTT) without any attention to standing training. Dobkin (2003) reported that

small randomized clinical trials of BWSTT have been carried out with favorable reports of at least short term gains as well as a variety of stepping parameters have been juggled by trainers, systematically or subconsciously, such as the levels of weight support and treadmill speeds, the duration of training session, and methods to optimize the kinematics, kinetics, timing of muscle bursts, and temporal feature of

the step cycle. The approach allows physical therapists to do hands on therapy under conditions they can control and vary within the learning paradigm they choose. In addition, for physical therapists, the use of BWST offers a neurophysiologically sound approach, but the actual requirements for assessing the legs of patients to optimize segmental sensory inputs and maximize the motor control available to patients as well as the best use of parameters such treadmill speeds and levels of weight support, are still being defined and tested (p. 264).

Yongqiang (2008) reported that 'standing is another important function in one's daily life, though it received less research attention than stepping' (p. 1).

1.2 Aim of the study

The aim of the study was to identify improvement in standing ability in children with spastic diplegia CP who are nonambulant after 21 weeks of standing training with manual BWS intervention conjunct with regular stretching exercises.

1.3 Operational Definitions:

Independent Variable: STBWS is a task specific training includes standing training in upright standing position using appropriate support for longest period of time and maximum repetition.

Dependent Variable: Improvement in standing ability in which child will be able to sustain own body weight on their lower extremities during upright standing as

well as maintain an extended position of trunk and lower extremities with arm free.

Population: Non ambulant children with moderate to severe spastic diplegia cerebral palsy who could not support own body weight on their lower extremities during standing.

1.4 Statement of Problem

Traditional physical therapy used in children with CP in the Gaza Strip tend to focus on improving muscle strength, local muscular endurance, and overall joint range of motion, but do not target to control standing and walking patterns of children with CP. Standing retention is the major problem in children with spastic diplegia CP who are nonambulant especially those who are after four years. Around the age of eight years, cerebral palsy mobility fails to improve, leading in some cases to wheelchair to confinement, this is due to increase mismatch between weight and strength as a result of spasticity (Medical Advisory Secretariat, 2005). No attention to standing training programs being used working with nonstanding children with CP. In order for children with CP to experience success in the development of standing, the intervention programs need to include specific training in standing position using appropriate support (Baird, 1983).

1.5 Significance of the Research

Green (1993) noted that “acquisition of standing skills is essential as a precursor to walking” (p. 15). Children who are able to walk are more successful in social roles and the accomplishment of activities of daily living (ADL) (Day, 2004). The demonstration of a non-cost effective approach to the training in standing

position could contribute to a more effective program approach for children with spastic diplegia.

This research conducted a standing training using manual BWS to identify improvement that occurred in both (1) standing, and (2) gross motor functions which preceded standing in nonambulant children with diplegia CP who could not support own weight on their legs over a period 21 weeks in contrast to other studies which concentrated on training for walking.

The approaches being used for children with CP in the Gaza Strip tend to focus on muscle and neurological training, but do not target to control standing and walking patterns of children with CP.

1.6 Research Question

Does an intensive training of the STBWS intervention conjunct with regular stretching exercises improve standing ability in children with spastic diplegia CP who are nonambulant?

Overview of Thesis

This thesis includes five subsequent chapters. Chapter 2 presents the study framework and the literature review. Chapter 3 provides a description of the methods used in this study. The results are presented in Chapter 4, with a discussion following in Chapter 5, which also includes conclusion of this research project, limitations, suggestions for additional applications and future work.

Chapter 2

2.1 Study Framework

Systematic reviews of selected topics related to STBWS trial as following: (a) benefits of standing in children with cerebral palsy; (b) normal motor development milestones; (c) motor development in children with CP; (d) process of motor learning; (e) test standing ability; (f) stages in development of standing; (g) reflexes of standing; (h) problems of commercially available standers; (i) learning standing up in a newborn infant wildebeest; (j) the development of posture; and (k) rationale for the development of an overground locomotor training system.

a. Benefits of Standing in Children with Cerebral Palsy

1. Standing has been shown to delay the appearance of contracture (Vignos, 1996).
2. Standing has been shown to decrease spasticity in cerebral palsy (Trembly, 1990).
3. Standing will increase the depth of child's acetabulum and decrease the risk of subluxation (Stuberg, 1992).
4. Standing also facilitates better emptying of bladder which decrease the risk of developing urinary tract infection (Dunn, 1998).
5. Dynamic weight bearing through lower extremities result in less of a loss in bone mineral density Thompson (2000) which can decrease the risk of developing of osteoporosis (Whedon, 1982), (Henderson, 2004).
6. Standing has been shown to improve circulatory, gastrointestinal, bowel and bladder, and respiratory function (Stuberg, 1992), (Dunn, 1998).
7. People who stand for at least 30 minutes a day have less pressure sores than those do not stand (Walter, 1999).
8. Stand will benefit psychologically. It will increase the child self-esteem by allowing the child to have eye to eye conversation with peers.

b. Normal Motor Development Milestones

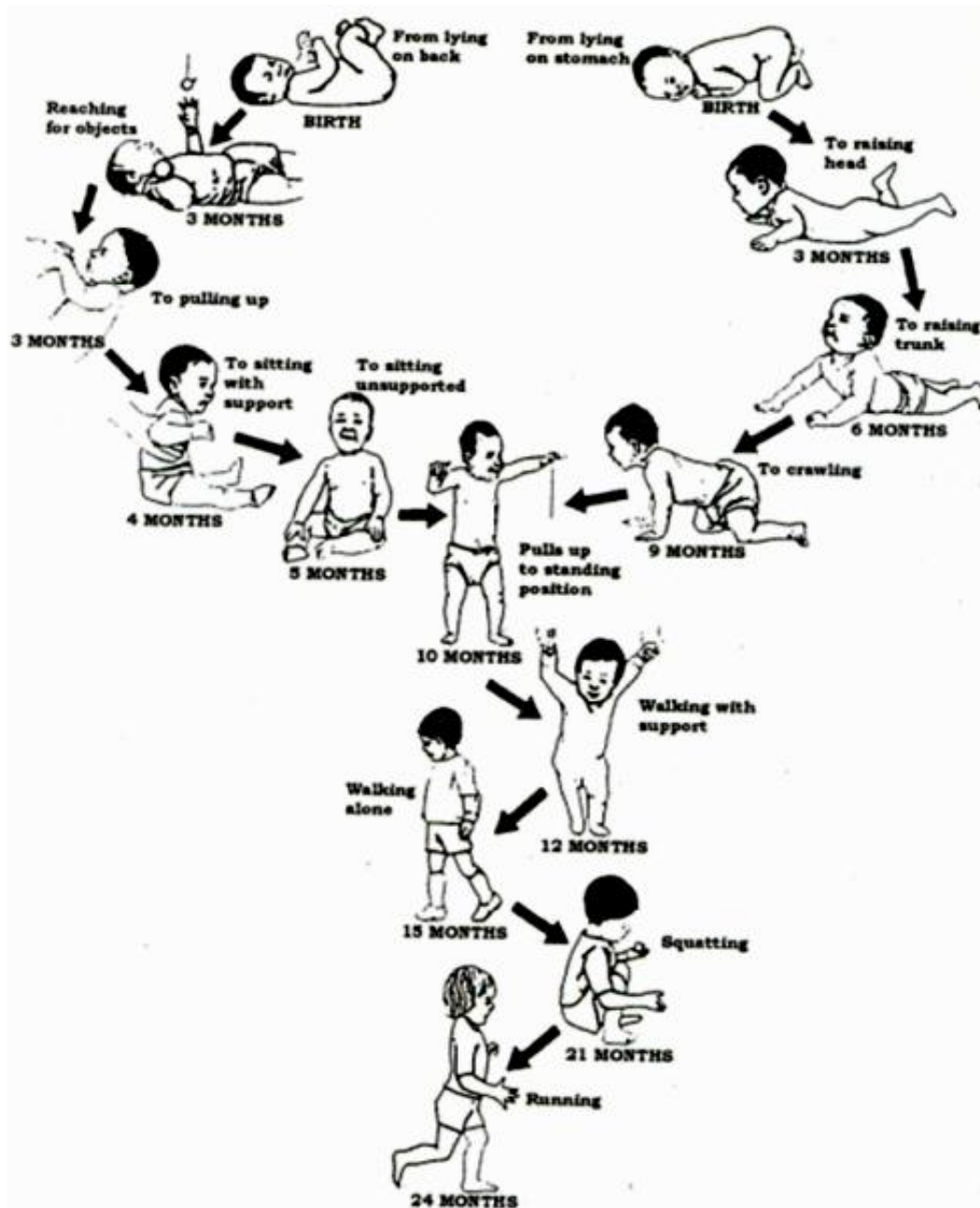

Figure 1: Development of strength and coordination in the movement of a child from birth to two years (known as motor development). Notice that (i) the process is one of continuous development, not steps and stages; (ii) the sequence is the same for all children (for example, head control always comes before sitting, sitting before crawling, etc.) but there may be many individual variations (for example, some babies do not crawl but progress straight to walking); and (iii) the age at which a particular motor skills is achieved varies with certain limits. (Illustration designed by Dr Pam Zinkin, Institute of Child Health). (Shukrallha, p.114)

c. Motor Development in Children with Cerebral Palsy

The rapid development of motor skills begins as the child moves about.

Movement abilities are those movement capabilities that we possess, the greatest force acting on the body during movement from birth is gravity. The ability of the young infant to maintain position in space is of primarily important to move his self against gravity. How reduce of development of antigravity posture may interfere with the child's adaptation to the physical environment and explore itself (Nasser, 1994).

The causes of the motor disorders are asymmetry, abnormal muscle activation and abnormal reflex reactions which can lead to deformities should have been inhibited in the normal motor development process (Nasser, 1994).

Seven basic principles of control of movement that should be considered as they pertain to motor control include muscle elongation, mobilization, body biomechanics, tonus gradation, balance muscle function, activation, and repetition (Connolly, 2005).

d. Process of Motor Learning

In a seminal article, Gentile (1972) addressed learning from an interactional point of view. That is learning is a function that emerge form an interaction of the individual and the environment to achieve the goal (Nasser, 1994).

Fitts and Posner (1967) have proposed three stages of learning: the Cognitive, Associative and Autonomous. The cognitive stage characterized by the learner's trying to learn what exactly the requirements of motor task. This stage has also been labeled verbal stage (Adams, 1971), because learners sometimes use self-talk the movement strategies. During this stage, learners tend to pay attention of relevant information related to a task (Nasser, 1994).

Learners at the associative stage begin to refine their skills. During this stage the learner will practice the skill in order to perform correctly and gradually eliminated errors (Fitts and Posner, 1967). It is essential that the learner gains feedback about their performance at this stage in order to generalize to new motor tasks (Adam, 1971) (Nasser, 1994).

In the final stage, the motor skills become very efficient and coordinated. In addition, the skills are performed automatically and required less dependent on cognitive control (Nasser, 1994).

e. Test Standing Ability

To test the infant's ability to stand, hold the child upright above the examining table. Note whether the child can support the body's weight well. Normal development of disability is as follows: Baker (2001)

1. Five months: able to support on weight; legs are semiflexed.
2. Eight months: able to stand with support, with trunk slightly forward and hip flexed.
3. Ten months: able to stand erect with support.
4. Twelve months: able to stand independently.

Primitive supporting reactions are tested by holding at least part of the infant weight. An infant younger than 2.5 months immediately stiffens the legs in extension ("positive supporting"). If the child is between 2.5 and 5 months of age, the legs may collapse as the infant is lowered toward the table ("astasia") (Baker, 2001).

f. Stages in Development of Standing; see figure 2



A. Weight bearing on legs (supporting reaction) (0-3 months). Body held.



B. Automatic stepping if infant is tilted forward, body held. (0-3 months).



C. Sinking or astasia (3-6 months). Head control.



D. Trunk supported standing and bouncing in standing (5-7 months).



E. Supported standing (5-7 months). Weight bearing of legs.

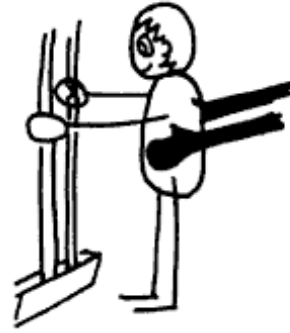

F. Stand holding on to support with pelvic support (7-9 months).



G. Stand holding on to furniture (7-9 months). Begin weight shift.

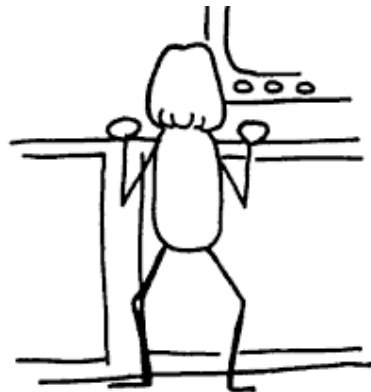

H. Pull up to standing from various positions (9-12 months).



I. Standing holding and lift one leg off the ground or one arm released (11 months).



J. Cruising (lateral stepping) (9-12 months).

Figure 4: Stages in development of standing (Levitt, 2004: p. 171-2).

g. Reflexes of Standing

1. The sway reaction or buttressing: By which a normal subject resists being pushed over when there is a horizontal force tending to push the body to one side, the leg on that side is extended more, and the foot is supinated, tending to oppose the horizontal force and keep the body vertical (UNSW, 2006).
2. The Stretch reflex: a major role of the stretch reflex is the maintenance of the upright standing posture. If one is standing upright and starts to sway forward, muscles at the back of the legs stretched, the spindle is stretched. Therefore, the muscles contracts, thereby bringing the body backward. In this way the current posture is maintained by alternate contraction and relaxation of these muscles (Oliver, 1991).
3. The positive supporting reaction: this is most easily seen in animals and in children up to 6-9 months old (Dekaban). If you hold your baby under his arms and allow his feet to come into contact on a flat surface, he will extend his legs cause a reflex increase in the tension of extensor muscle so that the limbs can support the load of the body (Rademaker, 1927, Schoen, 1926) (UNSW, 2006).

h. Problems of Commercially Available Standers

A **stander** is a device that helps a child stand; see figure 3 (Miller, 1995).

1. Currently available standers, although designed for children of low physical ability, do not provide postural control sufficient to improve a child's ability of prevent the progression of deformity (Green, 1993).
2. The standers do not reinforce the therapeutic principles of standing. The child is unable to adopt a normal developmental position to receive the appropriate sensory and biomechanical feedback necessary to learn how to stand. No stander provides pelvic stability whilst allowing the anteriorposterior sway necessary for balance stance (Green, 1993).
3. The adjustability of the standers is not sufficient to allow for the child's changing ability and growth (Green, 1993).
4. Except for the small upright standers, like the flexistand, transportation of standers is difficult, especially between school and home (Green, 1993).

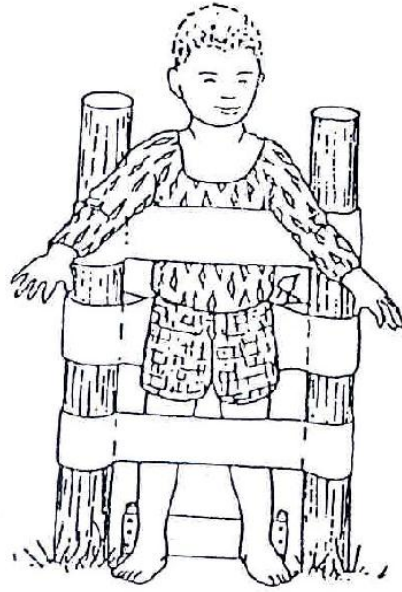

(A)

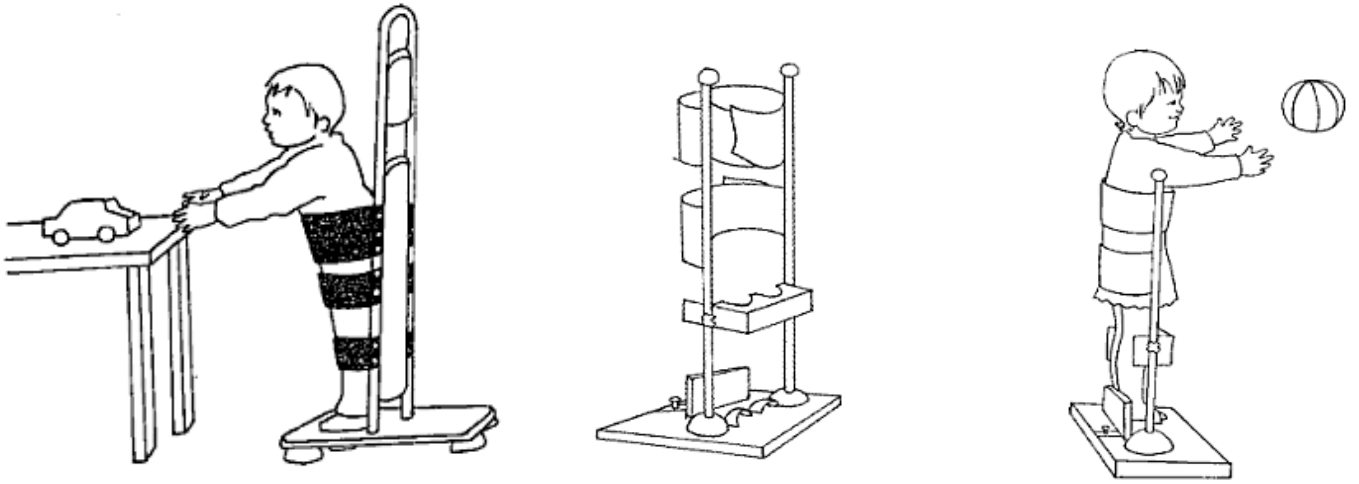

(B)

Figure 3: it showed examples of upright standers **A** (Werner, 1999), **B** (Hinchcliffe, 2007).

I. Learning Standing up in a Newborn Infant Wildebeest

The first visible action of a newborn infant wildebeest, after only a few panting breaths, is that the animal lift its head clear of the ground, using its neck muscles. The head then lurches about from side to side and up and down. The momentum developed during these lurches has to be absorbed by intermittent muscular activity. The coordinated timing of this activity in the relevant muscle group improves rapidly. Trunk muscles and limb muscles are soon brought into play. In place of the initial accidental lurchings of the head, the animal starts to make apparently deliberate lurching which affect the trunk as well as the head. Lurchings of the trunk affect the legs and then these in turn are brought into coordinated action, until the whole of forequarter, and eventually the hindquarters also, come clear of the ground. At this stage the infant's feet are widely spread, giving a very large area of support. With further lurchings, confidence improves, and the feet are brought gradually closer together. The infant is standing up within about three minutes from the moment of birth (Roberts, 1995).

It is the lurching movements of the head, passing the momentum to the trunk when each lunge is arrested, that makes it possible for the infant to lift one or other of its feet momentarily and to reposition it. The infant now staggers about, rapidly acquiring increasing skill in controlling both the aiming of the legs and the magnitude of their thrusts. In only about 20 minutes, the infant wildebeest is ready to move off with its mother to join the herd. In other species, where young are born in the protected environment of a nest or den of some kind, the various stages of development of the technique of standing and locomotion are very much more spread out in time (Roberts, 1995).

J. The Development of Posture (Jane, 2003)

By 2.5 months, development coordinated movements of the muscles in the cervical area and begin to use visual and vestibular interactions that permit for antigravity postural activity (Shumway-Cook & Woollacott 2000). This can be seen if the infant attempt to raise himself by her arms against gravity in supine position; during the newborn period the head will drop backward, and by 2.5 months the head travels in line with the back, and by 5-9 months the head will lead the shoulders.

Sitting requires coordination between neck and trunk muscles to support and hold the head erect in space, along with translation in lumbar and pelvic muscle control and relaxation in hip flexor muscles. Early sitting relies heavily on the visual system for postural cues. At 1-2 months of age, the infant will use visual cues to raise the head. By 3 months of age, there is improved control of the thoracic region but lumbar support is still lacking and the child relies on visual rather than proprioceptive cues for balance. In fact, a young infant can maintain an unsupported, sitting position if her head is stabilized. After 3 months, proprioceptive information from the hip and pelvis begins to dominate postural control.

By 8 months, most children can sit successfully and are able to correct for sway with appropriate muscle activity in the trunk and neck (Shumway-Cook & Woollacott 2000). When balance is perturbed, they will use their extended arms to maintain stability (the protective equilibrium response). Somatic strain in the torso may shift the child's centre of gravity forwards of their base of support (the pelvic). This can occur in children with torticollis. Breech position can also place abnormal stresses on the pelvis and lumbar spine, resulting in delayed or awkward independent sitting (chart review and physician survey).

By 6 months, the child can raise his head and shoulders and most of his chest from a prone position. This is accomplished through head, neck and torso control, rather than lifting with his arms. The hip and leg flexors are more relaxed and the child's pelvis can lie on ground. This is the position from which he will be able to initiate the commando crawl, wherein he uses his arms and torso to propel himself along the floor. In the early stages of this maneuver, the child primarily relies on the sinusoidal motion of his body rather than leg activity. In recent years, since the advent of recommendations to avoid the prone position for sleeping infants, many overzealous parents have completely avoided placing infants on their stomachs. They have noticed that some of these children will substitute a rolling maneuver for the commando crawl, therapy using torso coordination to propel themselves. In either case, as coordination of the lower extremity muscle groups develops, the child will engage his legs in the activity. Once the child can coordinate flexor and extensor activity in his legs, he needs only to cultivate lumbar and pelvic control in order to raise his body and crawl on his hands and knees (creep). The ability to creep usually coincides with ability to sit self-supported and the establishment of lumbar and pelvic control. Proprioceptive feedback is important in lumbopelvic mechanics. As previously mentioned, visual cues will strongly influence postural control in the first months of life; however, they will be quickly replaced by proprioceptive input.

The progression of developmental stages, it would appear that mapping of the sensory systems begins in the neck and extends into the thorax, trunk, lumbar and pelvic areas. As these sensory maps become more firmly established, the child will rely more upon somatosensory information and less upon visual input. A child who cannot establish appropriate or effective somatosensory maps will use visual input to maintain balance. Anecdotally, most children with cerebral palsy will exhibit

significant imbalance and unsteadiness if visual input is removed (clinical observation by the author and department staff).

Prior to 6 months, infants fail to stand; however, this is not due to muscle weakness since lower extremity muscle test at strength sufficient to support the child's weight (Roncesvalles & Jensen 1993). Rather, neural mechanisms, which are necessary for stance, are not sufficiently developed, electromyograms at 2-6 months demonstrate a lack of coordination between gastrocnemius, hamstrings, and tibialis anterior and quadriceps muscles when balance is threatened (Sveistrup & Woollacott 1993). By 7-9 months, there is improvement in ankle muscle control. This improvement will progress up the limb to include thigh and trunk muscles by 9-12 months (Shumway-Cook & Woolacott 1995. P. 158). Although practice on platforms will increase strength, it will not improve latency of activation, suggesting that the neural circuit must be mature in order to function (Stveistup & Woollacott 1997).

By 10 or 12 months, the child's balance is much improved, through postural strategies still involve torso and pelvis. Protective mechanism involving more controlled movement response involves. Posture and balance strategies are still quite immature. At this age, the child is still learning to use a combination of proprioceptive information from the spine, vestibular system, eye and somatosensory system into the complex sense of equilibrium. While children usually are able to pull themselves into upright position and accomplish supported standing, minor perturbations will easily disturb their stability. Even visual distraction can cause the 12-14 month old child to lose her balance.

K. Rationale for the Development of an Overground Locomotor Training System

One of the new advances in gait retraining is the development of an overground BWS strategy. Indeed, some differences between overground and treadmill gait parameters have been demonstrated in cats (Wetzel et al., 1975) and in nondisabled individuals (Arsenault et al, 1986; Murray et al, 1985; Savelberg et al, 1998; Stolze et al, 1997; Strathy et al, 1983; Van Gheluwe et al, 1994; White et al, 1998). During walking overground, the environment as seen by the individual is changing (open field), which is not generally the case on a treadmill. Speed is also internally driven during overground walking instead of externally driven as on treadmill. The rationale behind overground gait retraining is that the transfer of the acquired walking skills to the functional ambulation could be more challenging for both postures locomotion. Thus the skill transfer will be more complete (or maybe easier) because overground training challenging posture and locomotor in the same way as functional ambulation (Latash, 2004).

Summary:

This reviews of selected topics related to STBWS trial that influence the study perspective regarding the examination, is a guide for the intervention, and a framework for motor development behavior, including: (a) benefits of standing in children with cerebral palsy; (b) normal motor development milestones; (c) motor development in CP; (d) process of motor learning; (e) test standing ability; (f) stages in development of standing; (g) reflexes of standing; (h) problems of commercially available standers; (i) learning standing up in a newborn infant wildebeest; (j) the development of posture; and (k) rationale for the development of an overground locomotor training system.

In this section stages of motor learning were used for interpretation the mechanism of motor development. According to motor learning theory, motor recovery arises from the interaction of multiple processes including perceptual, cognitive and motor process within the individual, and the interactions between the individual, the task, and the environment. Stages in development of standing, learning standing up in a newborn infant wildebeest, and the development of posture also provide a theory of development of posture including upright standing as CP child shows similar muscle progression of postural muscle response development to what normal children, though delay by many months and these theories provides a basic ideas about the nature of function as well as a rehabilitation clinical practice for force functional recovery, that is, recovery obtained through specific interventions designed to have an impact on neural mechanism. Locomotor training with body weight support one of a new advance for function recovery including upright standing.

2.2 Literature Review

The aim of the study was to identify improvement in standing ability in children with spastic diplegia CP who are nonambulant after 21 weeks of standing training with manual BWS intervention conjunct with regular stretching exercises.

Larger numbers of preschool and school-aged children have been studied compared with infants and toddlers. More evidence exists regarding the efficacy of BWSTT on endurance, gait speed, and gross motor function related to ambulation than on balance in children with CP. Longer and more intense BWSTT protocols may lead to better results, that have been focused on walking only and have used sophisticated equipment. Richards et al (1997) first investigated the feasibility of applying treadmill gait training in four children with CP between the ages of 1.7 to 2.3 years. They received a combination of BWSTT and conventional therapy for a period of four months, four times per week. By using BWS through a harness, which was graded based on the child's needs, along with manual guidance of the lower extremities; the authors were able to show an overall improvement in GMFM of 23%. They concluded that 'treadmill training was feasible even before the children had development the ability of independent walking' (p.1).

Schindl et al (2000) conducted similar a non-randomized study of Treadmill with body weight support (TBWS) gait training as well as traditional physical therapy (PT) for three months in six nonambulant children with CP and in four children with CP who were ambulatory but who needed varying degrees of support. The children ranged in age from six to 18 years. Eight of the subjects found improvement in their motor abilities post training, such as transfers and sit to stand maneuvers. One subject, who was in the nonambulatory group prior to the BWSTT, was able to give up his

wheelchair usage at home after the three months of training. On the standing portion of the GMFM the mean increased from 10.9 to 15.9, and the walking score improved from 9.8 to 14.1. The improvement in the standing score demonstrates a 47% change, while that of the walking score shows a 50% change. They concluded that 'after 3-month program, 30 minutes per sessions, three sessions per week, and 36 sessions over all, and the children demonstrated significant improvements of motor function' (p.1).

McNevin et al (2000) conducted a study on a One medically stable 17-year-old female, classified as having spasticity her heart rate, blood pressure, and perceived exertion were recorded across increments in treadmill gait speed as a function of nonsupported and partial unweighting conditions (30% of body mass supported). The partial unweighting condition resulted in significantly lower physiologic (heart rate and blood pressure) indices and perceived exertion across all increments in gait speed. Additionally, the subject was able to ambulate at a faster rate of speed under the partial unweighting relative to nonsupported conditions. They concluded that the partial unweighting improves gait efficiency across increments in gait speed, but only to a certain point. For the subject in this report, gait efficiency declined as speed increased beyond some critical threshold (about 2.72km/h), suggesting a limit to partial unweighting during gait training as a function of endurance and training.

Song et al (2003) conducted a non randomized study of PBWS in 20 children under 10 years of age with mean age of 5.2 years. They were at level III or IV of Gross Motor Function Classification System (GMFCS), and were diagnosed as CP spastic diplegic type. They had received comprehensive rehabilitative management through the outpatient clinic for more than one year, but did not show specific

improvements in their gait patterns. They participated in three weeks of additional treadmill training, five times a week, for 20 minutes a session. After training result showed significant improvements in gait parameters. They concluded that 'treadmill training with PBWS is an effective treatment method to achieve better gait ability and walking velocity in children with CP' (p.1).

Bodkin et al (2003) conducted a research of treadmill training in children with cerebral palsy and a male infant, who had a grade III intraventricular hemorrhage following premature birth, began physical therapy and treadmill training at 5¼ months corrected age. Treadmill training was conducted 3 times weekly and videotaped weekly. After training result showed except for foot position, trends in treadmill stepping were similar to those of studies with infants not at high risk for neuromotor disabilities. They concluded that 'This case report shows that treadmill training is feasible for an infant at high risk for neuromotor disabilities and may be associated with more mature stepping characteristics' (p.1).

Blundell et al (2003) conducted a non randomized ABA study. Eight children with cerebral palsy aged 4-8 years, seven with diagnosis of spastic diplegia, and one of spastic/ataxic quadriplegia. They were practicing functionally based exercises including treadmill walking, step-ups, sit-to-stands and leg presses for four weeks of after-school exercise class, conducted for one hour twice weekly. After training result showed isometric strength improved by a mean of 47% (SD 16) and functional strength, on Lateral Step-up Test, by 150% (SD 15). Children walked faster over 10 m, with longer strides, improvements of 22% and 38% respectively. Sit-to-stand performance had improved, with a reduction of seat height from 27 (SD 15) to 17 (SD 11) cm. Eight weeks following cessation of training all improvements had been maintained. They concluded that 'A short programme of task-specific strengthening

exercise and training for children with cerebral palsy, run as a group circuit class, resulted in improved strength and functional performance that was maintained over time' (p.1).

Day et al (2004) reported a case study in which a nine-year old child with spastic tetraplegia CP who could not support his own weight and had never experienced walking. He participated in locomotor training that included BWSTT in 44 sessions for four months. In pre and post training tests, the child demonstrated improvements in all domains of the GMFM and both domains of the Pediatric Evaluation of Disability Inventory. He was able to complete up to 60 independent steps on the treadmill while supported in the BWS harness. Four months after training, he was able to walk over ground short distances with a rolling walker and minimal assistance. They concluded that 'BWSTT improves stepping on a treadmill with carryover to over-ground walking in a nonambulatory child of this age with spastic tetraplegic CP' (p.1).

Chan et al (2004) conducted a study to determine the effect of neuromuscular electrical stimulation on the triceps surae muscle in improving the gait and function of children with cerebral palsy 8 weeks (2-4-2 week design). Twelve children with spastic diplegia or hemiplegia were recruited and randomly assigned to the two experimental groups. The initial 2 weeks was the control period, in which usual treatment was given to both groups of patients with a pre- and post-treatment assessment. The middle 4 weeks was the experimental period, in which the Treadmill + neuromuscular electrical stimulation group received neuromuscular electrical stimulation plus treadmill walking training and the Treadmill group underwent treadmill walking training only. Assessment was performed at 2-week intervals. The final 2 weeks was the carryover period, in which treatment to be tested was stopped

and reassessment performed again at the end of week 8. In pre and post training tests, kinetic changes in ankle moment quotient and ankle power quotient were not significant either immediately or cumulatively in both groups. Improvement in trend was observed in both groups immediately but not cumulatively. Using the GMFM, functional changes were detected in standing (GMST, $p < 0.001$) and in walking (GMWK, $p = 0.003$) using a “time” comparison. Significant interaction was also detected in GMWK using “treatment by time” ($p = 0.035$). The difference between the two groups was not significant on “treatment” comparison of both GMST and GMWK. They concluded that 'Both the Treadmill+ neuromuscular electrical stimulation and Treadmill groups showed improvement in functional outcomes. The trend in the changes of the GMFM score suggested that improvements were greater in the Treadmill+ neuromuscular electrical stimulation group. There was also a trend showing some immediate improvement in ankle moment quotient and ankle power quotient' (p.1).

Stuberg et al (2005) conducted a study of PBWS in six children of CP; four out six had spastic diplegia, one had spastic hemiplegia, and one had athetoid quadriplegia. The children ranged in age from four to 17 years with a mean age of 10.2 years and the GMFCS range from level I to III. All subjects were able to walk independently at the start of the study, with or without assistive device. They participated in 12 weeks of PBWSTT for 20 minutes, three times per week. They showed that "treadmill training with PBWS was found to be an effective intervention to improve walking speed and endurance in children with CP' (p.1).

Unnithan et al (2006) conducted a study to assess the effect of PBWS on the oxygen cost of treadmill walking in children and adolescents with spastic cerebral palsy in five children. The children age is (12.4 ± 3.6 years). They participated in

three 4-min treadmill walks on three separate days at their comfortable treadmill walking speeds. At each visit a different partial body weight harness setting was used. They showed that Significant ($p < 0.05$) differences in oxygen cost were found when the harness was worn but not connected to the support frame. Partial body weight support reduces the oxygen cost of walking in children and adolescents with spastic CP.

Cherng et al (2007) conducted a study of eight children of spastic diplegic CP aged between three and seven years at level I-III of GMFCS. They attended a 12-week programmed including two to three sessions per week of BWSTT in addition to their regular therapeutic exercise programmed. The TBWS treatment significantly improved the children's gait (increases in stride length and decreases in double-limb support percentage of gait cycle) and their GMFM (dimension D and E scores as well as the total score). No significant improvements on muscle tone or selective motor control were noted. They concluded that the 'TBWS treatment improved some gait parameters and gross motor functions in children with spastic CP' (p.1).

Moreover, Provost et al (2007) reported improvement in four out of six ambulatory CP children aged from six to 14 years who had GMFCS level I and were able to ambulate independently without assistive devices. They participated in 30 minutes treadmill training sessions twice daily, six days per week for two weeks of intensive program of BWSTT. Pre and post training tests showed significant improvements on walking, and four of six showed improvement of 1%-9% on a GMFM score, although the overall improvements on these tests were not statistically significant. They concluded that 'an intensive, 2-week, BWSTT protocol is effective

in this population for improving walking speed and efficiency, and in some cases for improving functional gait, balance, and endurance in school-age children' (p.1).

In addition, Begnoche et al (2007) combined intensive physical therapy and BWSTT in a study of five children with spastic CP. The children age range from 2.3 to 9.7 years participated in a therapy program for four weeks, three to four sessions per week, for two hours per session. All five children showed significant improvements in motor and ambulatory skills. They concluded that 'an intensive episode of physical therapy of reasonable frequency and duration that includes PBWSTT may be effective in improving motor skills of children with spastic CP' (p.1).

Dodd and Foley et al (2007) conducted a small, controlled clinical trial of 14 CP children. Children in this study had GMFCS level III (four patients) or IV (ten patients) indicating a moderate to severe walking disability. Six had athetoid quadriplegia, six had spastic quadriplegia, and two had spastic diplegia. A total of seven children aged from five to 14 years (mean of 8 years 9 months) were recruited for the experimental group, and seven others matched for gender, age, type of CP, and GMFCS level served as controls. Those in the experimental group walked on the treadmill using PBWS twice weekly for a maximum of 30 minutes per session for the 6-week study period in a school-based program. Control patients continued normal activities, which could include therapy but not treadmill training. Compared with controls, those in the experimental group showed significant improvements in walking speed in the experimental group, and no change in the control group. They concluded that 'PBWSTT increases walking speed in children with moderate to severe walking disabilities, and may improve endurance of "over ground" walking, noting

that this type of training can be done in the school setting and doesn't require a great deal of time or expensive equipment' (p.1).

Phillips et al (2007) conducted a pilot study to investigate the feasibility of using functional magnetic resonance imaging as a physiological marker of brain plasticity before and after an intensive body-weight-supported treadmill training (BWSTT) program in children with cerebral palsy (CP). Six ambulatory children (four males, two females; mean age 10y 6mo, age range 6-14y) with spastic CP (four hemiplegia, two asymmetric diplegia, all Gross Motor Function Classification System Level I) received BWSTT twice daily for 2 weeks. All children tolerated therapy; only one therapy session was aborted due to fatigue. With training, over ground mean walking speed increased from 1.47 to 1.66m/s ($p=0.035$). There was no change in distance walked for 6 minutes (pre-: 451m; post-: 458m; $p=0.851$). In three children, reliable functional magnetic resonance imaging were taken of cortical activation pre- and post-intervention. Post-intervention increases in cortical activation during ankle dorsiflexion were observed in all three children. This study demonstrates that children with CP between 6 and 14 years of age can tolerate intensive locomotor training and, with appropriate modifications, can complete a functional magnetic resonance imaging series.

Meyer-Heim et al (2007) conducted the first pediatric trial to determine the feasibility of robotic-assisted treadmill training for 26 children with central gait impairment mean age 10 year 1 month and at level II to IV of GMFCS. Diagnoses of the study group included cerebral palsy (n=19; Gross Motor Function Classification System Levels I-IV), traumatic brain injury (n=1), Guillain-Barré syndrome (n=2), incomplete paraplegia (n=2), and haemorrhagic shock (n=1), and encephalopathy

(n=1). Sixteen children were in-patients and 10 were outpatients. They received robotic-assisted treadmill training enabled by a driven gait orthosis for 19 sessions in the in-patient group and 12 sessions in the outpatient group. Functional Ambulation Categories and standing dimension (in-patient group $p<0.01$; outpatient group $p<0.05$) of the gross motor function measure improved significantly. Driven gait orthosis training was successfully integrated into the rehabilitation programme and findings suggest an improvement of locomotor performance.

Borggraefe et al (2008) conducted a trial of robotic-assisted locomotor treadmill therapy to improve walking in children with central gait impairment for three weeks. A 6-year-old boy with bilateral spastic cerebral palsy. The result showed improved function, speed, and endurance of walking. They concluded that 'The boy tolerated the trial very well and showed improved function, speed, and endurance of walking' (p.1).

Cernak et al (2008) described the effects of locomotor training using body-weight support (BWS) on a treadmill and during overground walking on mobility in a child with severe cerebellar ataxia who was nonambulatory. She received a locomotor training using a BWS system both on the treadmill and during overground walking was implemented 5 days a week for 4 weeks in a clinic. Locomotor training using BWS on a treadmill was continued 5 days a week for 4 months at home. The results showed that prior to training, she was able to take steps on her own with the help of another person, but did not take full weight on her feet or walk on a regular basis. At 6 months, she walked for household distances. Prior to training, her Pediatric Functional Independence Measure scores were 3 (moderate assistance) for all transfers, 2 (maximal assistance) for walking, and 1 (total assistance) for stairs. At 6 months, her

scores were 6 (modified independence) for transfers, 5 (supervision) for walking, and 4 (minimal assistance) for stairs. Prior to training, she was unable to take independent steps during treadmill walking; at 6 months, all of her steps were unassisted. They concluded that 'Locomotor training using BWS on a treadmill in conjunction with overground gait training may be an effective way to improve ambulatory function in individuals with severe cerebellar ataxia, but the intensity and duration of training required for functionally significant improvements may be prolonged' (p.1).

Meyer-Heim et al (2009) conducted an experimental study of 22 children of CP mean age 8.6 years and at level II to IV of GMFCS. They received robotic-assisted locomotion training for 3-5 weeks, 3-5 sessions of 45-60 minutes/ week. Pre and post training tests showed significant improvements on the gait speed as well as the mean on the dimension D of the GMFM-66 increase from 40.3% to 46.6%. While the mean on the dimension E of the GMFM-66 increased from 29.5% to 31.6% did not reach a statistically significant level. They concluded that 'children with CP benefit from robotic-assisted gait training in improving functional gait parameters' (p.1).

Willoughby et al (2010) conducted a randomized control study of thirty-four children classified level III or IV by GMFCS were recruited and randomly allocated to experimental or control groups. Of these, 26 (15 girls, 11 boys; mean age 10 years) are completed training and testing. Both groups completed 9 week of a twice weekly walking training. The experimental group completed PBWSTT and the control group completed overground walking practice. Compared between groups, the overground walking group showed a trend for an increase in the distance walked over 10 minutes. There was no statistically significant difference in self-selected walking speed over 10

meters or in walking function in the school environment as measured by the School Function Assessment. They concluded that 'PBWSTT is safe and feasible to implement in a special school sitting however it may be no more effective than overground walking for improving speed and endurance for children with CP' (p.1).

Finally, Borggraefe et al (2010) conducted a trial of robotic-assisted treadmill therapy for three weeks. Participants are 20 patients (mean age 11.0 ± 5.1 , 10 males and 10 females) with CP underwent 12 sessions of robotic-assisted treadmill therapy using the driven gait orthosis Lokomat. Outcome measures were the dimensions D (standing) and E (walking) of the GMFM. Results showed that significant improvements in dimension D by 5.9% (± 5.2) and dimension E by 5.3% (± 5.6) of the GMFM were achieved. They concluded that 'children and adolescents with bilateral spastic CP showed improvements in the functional tasks of standing and walking after a 3-week trial of robotic-assisted treadmill therapy' (p.1).

Summary

BWSTT is a rehabilitation method that has shown early success in helping some children with CP in developing the ability to walk. Cerebral Palsy while this group contains a large number of studies by far, 21 are presented in this study. Despite the increased number of studies in CP and other central motor disorders, the strength of the evidence is generally weak with no randomized clinical trial performed to date to address the efficacy of this intervention. The one level II study included here compares two types of treadmill training paradigms, with both groups showing significant increases in GMFM scores on the 'Standing' and 'Walking, Running, Jumping' Dimensions over time (Chan, 2004). Since the study did not include a 'no treatment' condition, however, the ability to draw conclusions is limited. The strongest research available to address intervention effectiveness is a single level III study by Dodd and colleagues which is a non-randomized controlled trial comparing two matched cohorts, one receiving the intervention and one serving as a control group (Phillips, 2007). That study did show a significant effect for increased gait speed in the training group during a ten meter walk at the subjects' self-selected comfortable speed. Distance walked in 10 minutes was substantially higher (by nearly 20 meters, on average) in the treatment group, but this result did not reach significance most likely because of the small group size (n=7) and the variability across subjects in the amount of change. All of the other studies are with a limited number of statistically favorable effects. Some positive effects emerged from across the multiple studies, but each outcome measure that showed positive results in one or more studies also had inconclusive or equivocal results in one or more other studies. For example, changes in self-selected gait velocity and in the GMFM dimensions D & E were the most frequently noted positive results, and they were also among the most

frequently reported results that either did not show a difference or were inconclusive.

Lower quality ratings were largely a function of the lower level study designs. A major weakness in this group of studies was the presence of co-interventions which may have had large distorting effects. In some cases, the results may have been more closely related to the other interventions than to the intervention of interest. For example, the study by Blundell and coauthors (2003) was primarily intended to increase strength, with treadmill training as one of many methods employed. Consequently, many of the outcome measures were assessments of functional strength and showed positive results that corroborated the isometric strength results. It is likely that the other strength training interventions had a larger effect on that outcome than the treadmill training component did. Other studies included botulinum toxin or recent surgery immediately before the intervention (Meyer-Heim, 2007), (Borggraefe, 2008), both of which could have potentially large positive or negative effects on outcomes depending on timing with respect to the treadmill training, muscles or joints addressed, and the aggressiveness or invasiveness of treatment. A randomized clinical trial of patients with CP completed in 2010 with least short term gains (Willoughby, 2010).

In summary, the strongest evidence, a single Level III study Dodd (2007), suggests that BWSTT is effective in increasing self-selected gait speed. While other positive statistically supported outcomes have been identified, any positive effects found are small and may not all be of clinical significance. The weakly positive or inconclusive outcomes from these pediatric studies are similar to those reported in other adult neurological conditions. This intervention has findings are similar to the finding reviewed by Palisano (2004) that treadmill training with partial body weight support has been successful in improving performance on both standing and walking

sections of GMFM in a group of nonambulatory children with CP (Schindl, Forstner, Kern, & Hesse, 2000). Improved GMFM scores (Cherng et al 2007). Because the current study used standing task training with nonambulant CP who could not sustain own weight on their legs; there is no direct comparison of these results can be made with the findings of previous studies as there is no attention to standing training programs being used when working with nonstanding children with CP.

Larger studies including control and treatment comparison groups are necessary in order to determine efficacy foremost, and whether the effort and expense associated with locomotor training with body weight supported, in terms of equipment as well as therapist and patient time, are justifiable.

There is some evidence to indicate that sustained stretching is preferable to manual stretching in improving range of movement and reducing spasticity in targeted joints and muscles in studies of children with spasticity (Pin, 2006).

Green, et al (1993) reported that:

scientific studies have shown that 30 minutes continuous

stretching daily is sufficient to prevent shortening of muscles.

Standing in the developmental position for a period of at least

30 minutes each day should prevent shortening of the Achilles

with cerebral palsy. Muscle shortening and consequent change

in the length/tension relationship of muscle known is known to be

contributory factor in the development of spasticity. If muscle

length can be maintained then spasticity may be reduced (p. 14).

Mayston (2001) reported that 'Stretching (Tremblay et al, 1990), and stretch via weight bearing (Walshe et al, 1994), have also been used to reduce the effects of so-called spastic muscles' (p. 58).

Chapter 3

Methodology

The aim of the study was to identify improvement in standing ability in children with spastic diplegia CP who are nonambulant after 21 weeks of standing training with manual BWS intervention conjunct with regular stretching exercises.

3.1 Design

Pre and post test design was used over a period of 21 weeks of standing training with manual BWS intervention conjunct with regular stretching exercises.

Subjects

Initially 223 children with diplegia CP children aged from 4-8 years were selected from lists obtained from local rehabilitation-based institutions in the Gaza strip, see appendix 8. Home visits were made by a researcher to all of these children over a period of four months. The purpose of the home visit was to select children who met the criteria for the inclusion of the study. Thirty out of 223 children were the only children who met the inclusion criteria. Nineteen children were randomly selected from the 30 to participate in the study program, four children of them discontinued the training after 10 weeks of STBWS program; three children of them traveled for surgical operations and the fourth refused to continue therapy, so they withdrawal from the sample. Inclusion criteria for participants in this study were (a) diagnosis of moderate to severe pure spastic diplegia CP, (b) age between 4 to 8 years old, (c) good mental ability, (d) GMFCS rating of III-IV, see appendix 5, (e) no surgical treatment during the preceding six months before study onset, and (f) no other disability or complex deformity, see table 1, and appendix 1. Parental

Permission was obtained from each subject prior to their participation in this study , see appendix 3.

Table 1: clinical characteristics of the participants.

Mean age (years)	6 y 5 mo (2.11)
Sex (n)	
Female	4
Male	11
Type of CP (n)	
Diplegia	15
GMFCS level (n)	
III	8
IV	7
% BWS in the Simple Easy Walk Machine in upright standing (Averages)(Stander deviation [SD])	42.33±10%

3.2 Outcomes Measurement

Instrumentation; see appendix 4.

Acquisition of motor function over a period of 21 weeks of STBWS was assessed with the GMFM-88. The GMFM is an evaluative, standardized, criterion-referenced observational instrument designed and validated to measure changes in gross motor function over time in children with CP (Campbell, 1999).

Total score is aggregate of all scores of all dimensions (Russell, 1993).

The GMFM is used to assess how much of an activity a child can accomplish rather than how well a child accomplishes the activity (Russell, 1993).

Although the GMFM is highly reliable, valid, and sensitive to change in a child's motor functions (Russell et al, 1989), its scores do not reflect components of a child's psychological fitness (Parker et al, 1993). Also there is a wide range between score (2) and score (3) (Russell, 1993).

Prior to performing each task, the child was instructed by the assessor how to do the activity. Three attempts were given to each activity whenever needed (Russell, 1993).

Measurement

Assessment for 15 children was made in accordance with the GMFM-88 guideline manual (Russell et al, 1993). Assessments before and after the program were undertaken by the researcher to the children in their homes. A pilot study for the GMFM-88 instrument by the researcher had practiced administering and scoring the GMFM-88 with three children before the main study onset and these three children

were excluded from the study. After a pilot study for the instrument, nothing was change on administering the GMFM-88 instrument.

Spasticity Assessment

It has been assessed with the Ashworth scales and applies once at the beginning of the study for all CP children participated in this study and used for measuring the resistance for spastic muscle of the lower extremities to quantify muscle tone. No validity or reliability test was done for this scale by a researcher. Ashworth (1964) who is the first to described the principle of muscle-tone assessment. He developed a 5-point scoring scale that determined the degree of resistance encountered in a specific muscle group by passively moving a limb at one (non-) specified velocity through its ROM. The Ashworth scale is the most used semiquantitative clinical scale to assess the spasticity Gelber (2002) see appendix 6. This scale is not very reliable (Mutlu, 2008).

Equipment

A simple easy walk machine with a harness in this study was only assessed once and used for quantifying the amount of external BWS by using weights in kilograms (kg) that assisted the child to over ground standing and/or stepping. This system consists of overhead pulley suspension machine with a medium designed harness. The suspension with the harness held the child securely and allowed the child to practice standing and/or walking with partial weight bearing. Figure 4: show a CP child equipped with a simple easy walk machine with a harness at El-Shifa hospital in Gaza.



Figure 4: cerebral palsy child equipped with a simple easy walk machine with a harness at El-Shifa hospital in Gaza.

3.3 Training Program

BWS technique relied on manual assistance of one and/or two trainers (i.e. a therapist ± a caregiver) during therapy session. The therapist would support partial amount of the child's body weight at adjustable site (e.g. at the pelvic region), by her hands, that would promote erect upright standing and maximum weight bearing on his or her lower extremities, while the caregiver might provide manual assistance to stabilize the child's knees or feet during stance according to the child's standing stability.

STBWS Training program; see figure 5

Child who has a limited standing ability might need at first to build up standing ability at upright position (i.e. to build up standing posture and maintain balance during supporting) by increasing the child's ability to support his or her body weight actively against gravity during upright standing. This could be trained on overground by providing partial amount of BWS at adjustable site (e.g. pelvic or knee level) of the child's body that promoted erect upright standing with maximum weight bearing on his or her lower extremities as much as possible by a therapist's hands, while a caregiver might provide manual assistance to stabilize the child's knees or feet during stance according to the child's standing stability. This gives the child an opportunity to practice upright standing and participates in supporting the none or less supported part of his or her body actively against gravity during over ground or on one meter height from the ground; to increase child's active participation for longest period of time and for maximum repetition. Interrupted short rest periods would be permitted during a session.

The amount and site of BWS would be determined during a session by the trainer according to his or her judgment and according to the child's ability to support his or her body weight during upright standing, to be sufficient to avoid pelvic and/or knees collapse.

The amount and the site of the child's BWS decreased gradually with time to and as a result of the child ability to support his or her body weight actively against gravity with joints stability during upright standing is improved.

The upright standing training will continue until the child's ability to support his or her full body weight actively on his or her lower extremities during upright standing is mature without knees or body collapse and the trainer provides a support for only maintaining a child's standing balance.



Figure 5: cerebral palsy children undergoing STBWS therapy at their homes.

Regular Stretching Exercise Program; see figure 6

The stretching program was set to meet needs and abilities of children with conjunction to the study program at the same session. The goals of this program were to normalize muscle tone, maintain or increase the joint ROM, and improve motor function to prepare the child's upright standing posture alignment and comfortable standing position for effective standing training and motor performance. The program precedes the study program and comprises mat exercises of ROM, stretching for back and full stretching exercise of adductors, flexors, hamstrings, and calf muscles of the lower extremities, and simple motor function activities.

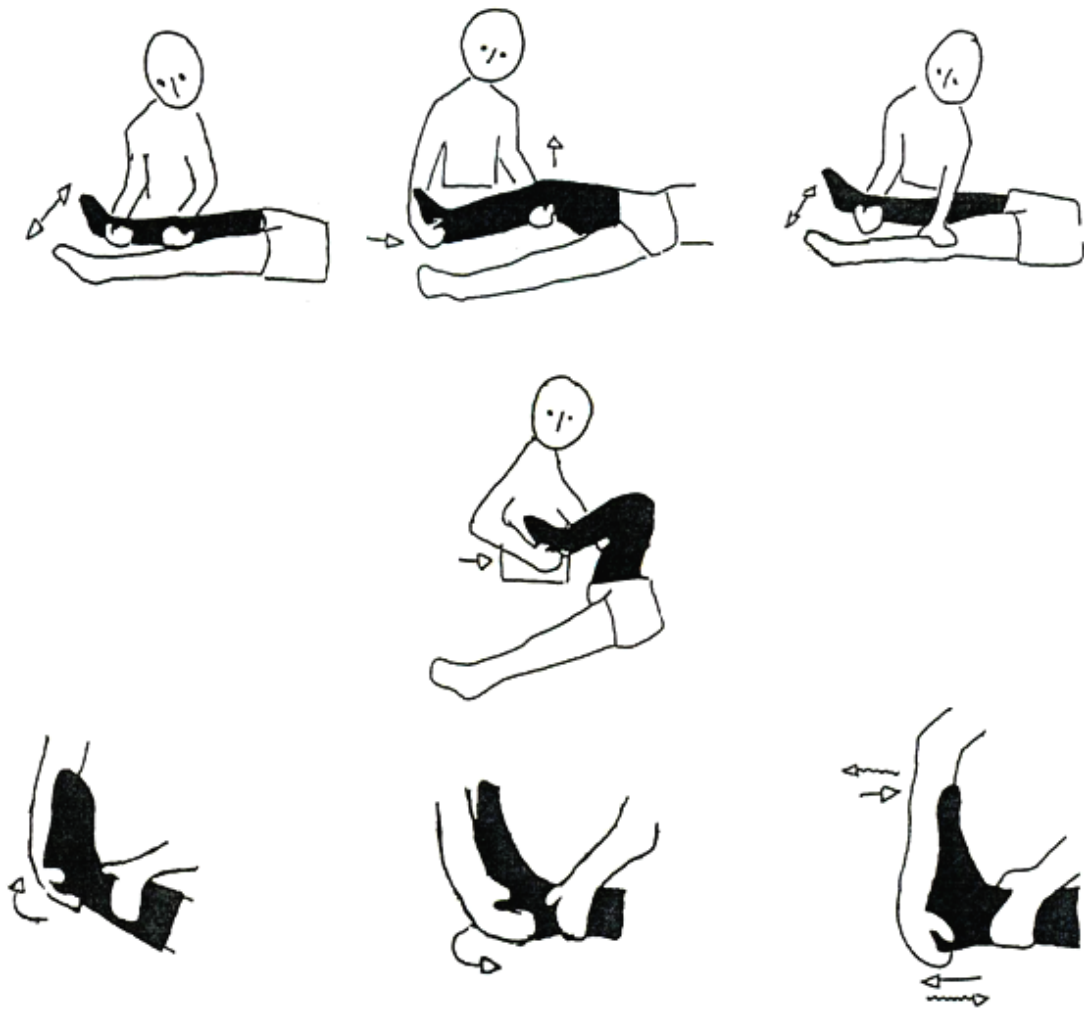

Figure 6: examination of joint mobility of different joints in Shukrallah' (2004) childhood disability project: final progress report, p. 119 (the figure showed examples of stretching of different joint similar to what have used in STBWS program).

Training sessions were scheduled as follows: two training session per week for 18 weeks of STBWS intervention over a period of 21 weeks with a four-week break. The first three breaks were in the end week of the first three months of training due to a perceived need as reward for hard work, and one week before the last month was due to Fasting Eid holiday. The children missed several sessions because of illness.

Every child received a total of (30±8) training sessions. Each session lasted between 45 minutes to one-half hours, see table 2.

Table 2: training session summaries.

Session (month)	Stretching time (Averages) (min)	Standing time (Averages) (min)	Rest time (Averages) (min)	Total Session time (Averages) (min)
May	30	15	8	53
June	19	17	11	47
July	19	23	11	53
August	20	25	10	55
September	21	29	8	58
October	24	24	8	53
Total	22	22	9	54

3.4 Statistical Analysis

The study design was pre and post test design based on the pre-STWBS and post- STWBS treatment, especially the improvement in the standing ability of the children with spastic diplegia who are nonambulant over a period of 21 weeks. However, it was considered important to include a statistical analysis of overall improvement demonstrated on the children according to scores obtained on the measurement tool GMFM-88.

The pre-STBWS and post- STBWS treatment mean scores of GMFM sections for participants after 21 weeks training period were analyzed with nonparametric Wilcoxon test, to determine whether any significant differences existed. The alpha level was 0.001 for all statistical tests (two-tailed). Statistical analysis was performed with Statistical Package for the Social Sciences (SPSS) version 13.0.

Chapter 4

Results

The aim of the study was to identify improvement in standing ability in children with spastic diplegia CP who are nonambulant after 21 weeks of standing training with manual BWS intervention conjunct with regular stretching exercises. Therefore, the results address changes that occur in both total goal of gross motor functions and standing dimension of GMFM-88 of children.

4.1 Effect on Dimension A, B, C, and D of Score of GMFM

Mean and SD for the dimension A, B, C, D, and total goal score of GMFM-88 pre treatment and post treatment measures for subjects are given in Table 3.

Table 3: the group means and SD for the dimension A, B, C, D, and total goal score of GMFM for subjects at two measurement times.			
	Mean±SD		Mean±SD
Dimension A			
T1	88.20±09.78	T2	92.80±04.79
Dimension B			
T1	70.46±27.16	T2	81.93±20.21
Dimension C			
T1	43.26±33.46	T2	52.86±33.41
Dimension D			
T1	10.00±08.65	T2	15.60±12.26
Total			
T1	53.13±17.42	T2	61.07±16.61

T1=pre test measurement.

T2=post test measurement.

The Wilcoxon test between the initial and final measurements for subjects revealed a highly significant differences in the dimension A, B, C, and D of GMFM-88 scores ($z=-3.411$, $df= 14$, $p<0.001$, 99.99% CI 1.51 to 14.35). Improved significantly from 53.13 to 61.07 (SD 4.63; see figure 7).

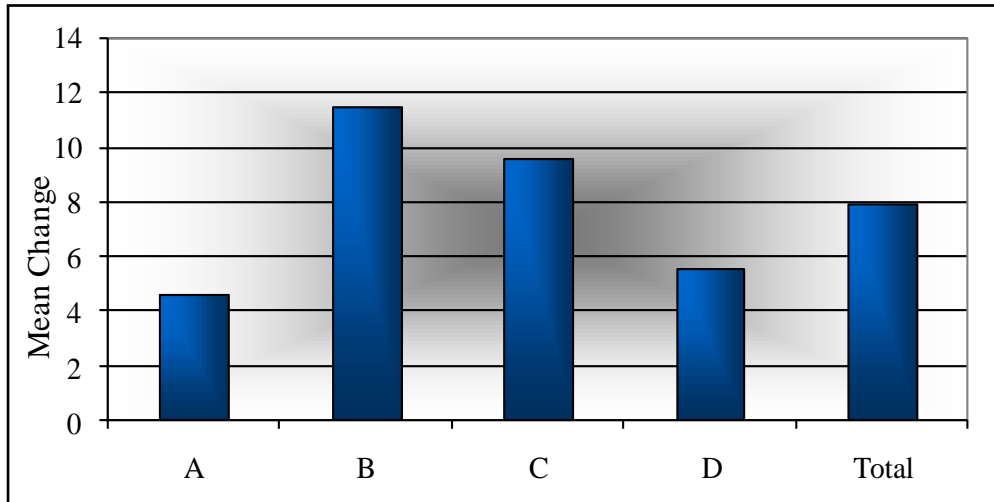

Figure 7: mean change scores in the dimension A, B, C, D, and total goal score of GMFM-88 for children following participation in the program of STBWS.

Therefore, STBWS program had a significantly positive effect on gross motor function in the children.

4.2 Effect on Standing Dimension Score of GMFM

The Wilcoxon test between the initial and final measurements for the children revealed a highly significant differences in standing dimension of GMFM-88 scores ($z= -3.343$, $df= 14$, $p<0.001$, 99.99% CI -0.58 to 11.78). The standing score from the Gross Motor Function Measure increased from a mean of 10.00 to 15.60 (SD 4.46; see figure 8) after the treatment.

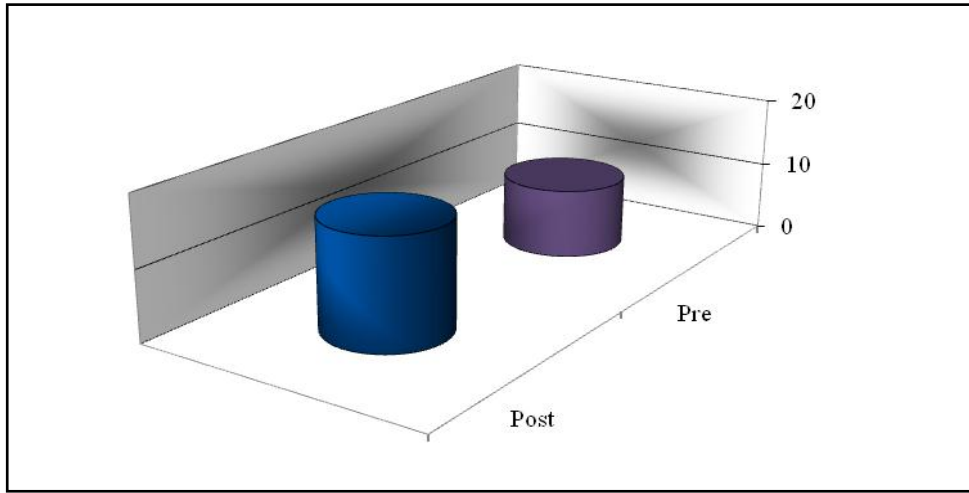

Figure 8: mean score of standing dimension of GMFM-88 for children between initial and final assessments.

Therefore, STBWS program had a significantly positive effect on standing dimension of gross motor function in the children.

Overall Change in Motor Function:

The mean change calculated from the four dimensions of GMFM scores, i.e. (lying and rolling, sitting, crawling and kneeling, and standing) over two measurement times of the study is presented by figure 9. This figure shows that after STBWS intervention overall improvement was obtained in all dimensions of the total goal of GMFM. The most improvement was shown in activities included in sitting 36%, creeping and crawling 31%, and standing 18%. The least improvement was in activities of lying and rolling 15%. The lack of significant changes in dimension A was probably attributable to the children' nearly full scores on this dimension at the baseline.

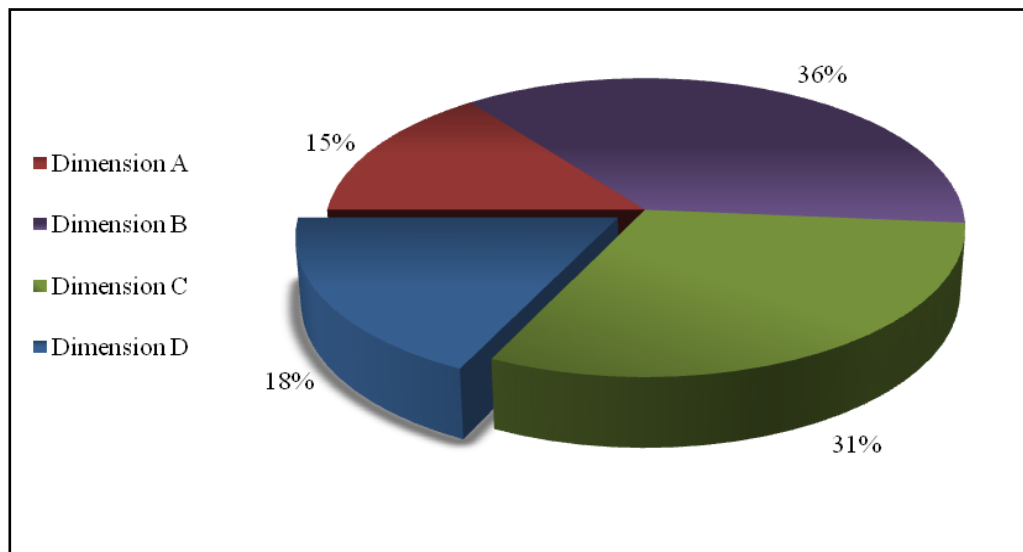

Figure 9: percentage of mean change in total changes of the dimension A, B, C, D of GMFM-88 scores of children after the effect treatment of STBWS.

4.3 Description of the result

Changes on Dimension A, B, C, and D of Score of GMFM after STBWS intervention

On Lying and Rolling Dimension:

Scores of this dimension showed that after treatment, four children improve the quality of their motor performances, while eleven children had no change.

These four children succeeded to show obvious improvements in their lying and rolling abilities. Two children of them with spastic diplegia (level III) who had dynamic sitting balance at pre testing but their lying and rolling dimension percentage mean score for both was 79% at pre-test. For these two children the percentage mean change in this dimension was 18%. At post testing, they get a score on the same items: from 1 to 3 on items 8 & 9, and from 1 to 3 on items 14 & 15, and from 2 to 3 on items 16 & 17.

Another male spastic child at (level IV) of this subgroup who had poor gross motor function as he got the least percentage mean score in the lying and rolling dimension of GMFM among the children which was 65%. The child after STBWS program successes to show obvious improvement in his lying and rolling dimension of GMFM as he gets a score from 0 to 3 on items 8, 9, 14, and 15. If one notes he also achieved improvements in the same items to the items of the previous two children of the same subgroup. He is unable to roll from prone to supine at pre-test shifted to 90% at post testing. Also he got a score from 2 to 3 on item 11.

The fourth child of this subgroup who had shortening in the flexors muscles of his upper extremities (i.e. flexion deformity in upper extremities) showed some

improvements in lying and rolling dimension of GMFM. He got a score from 1 to 2 on item 7, and from 2 to 3 on items 13, and 17. If one notes the improvement concentrate on upper extremities that assess lying and rolling function despite there is a little concentration on stretching exercise to upper extremities.

Statistically, the changes obtained in this dimension at the end of the therapy program were not significant.

On Sitting Dimension:

Results of this dimension show that after the STBWS program, improvement has taken place in twelve children, while three children did not change their level of motor function in sitting.

Individual tests to five children who were able to sit on mat with arms propping five seconds at pre-test, three children from them at post testing get a score of 3 on item 24 of GMFM-88, and the remaining two children become able to sit with one hand support. Because most of these children become able to sit with arm free with better balance and for longer, they progress from static sitting to dynamic state and lead to a magnitude of change on this dimension demonstrate on items 19, 20, 25, 26, 27, 30, 33, 34, and 36.

The other six children, although four children of them had the ability to perform most of the specific task while maintaining the sitting position at pre testing, and two children of them scored 80% on baseline assessment; on re-testing, the sitting dimension scores of GMFM had increased to full or nearly full scores in five children of them. The mean change in sitting dimension of GMFM-88 for three children of

them is 17%. The improvement in sitting in this subgroup was seen with a score from 1 or 2 to 3 on items 19, 20, 28, 29, 31, 32, 33, 34, and 35.

Another male spastic CP child (level IV) who initially achieved a GMFM sitting percentage mean score of 52% and who had a problem in spasticity as well as he had no dynamic sitting balance. This child shows only some improvements in this dimension.

The remaining three children who had full and nearly full scores in sitting dimension of GMFM at both testing periods, meaning they may be unable to be assessed for further improvement by using STBWS program.

Statistically, the changes obtained in this dimension at the end of the therapy program were statistically significant.

On Crawling and Kneeling Dimension:

Dimension C (Crawling & kneeling) showed the second highest mean change at post testing. Thirteen of fifteen children showed improvements in all items of this dimension.

Six children showed notifiable improvements in their creeping and crawling abilities after treatment program, but the nature of improvements are vary according to their original conditions. So these six children are divided into two subgroups. The first subgroup which consist of three children who had crawling percentage mean scores of 74% and all of them get a score of 3 on item 44 as they able to hitch or move forward in four point on baseline assessment. At post testing, the improvement in GMFM was seen with various scores on items 38, 45, 46, 47, 48, 49, 50, and 51.

The second subgroup which consist of two very spastic diplegic male children (level IV) and one female moderate spastic diplegic (level III), who got low gross motor scores: 21%, 31% for two male children and 14% for female child on their crawling percentage scores at pre-testing. At post testing, the children displayed obvious improvements at their crawling abilities as the first child got a score from 2 to 3 on items 39, and 40; from 1 to 2 on items 41, and 48; from 0 to 2 on items 42, and 43; and from 0 to 1 on item 51. The second child got a score from 0 to 3 on items 42, 43, and 44; and the female child got a score 1 to 3 on item 43; from 1 to 2 on items 40, 41, and 42; and from 0 to 1 on item 48. Despite the spasticity problems and poor gross motor ability in these children, they succeeded to show this magnitude of change (i.e. percentage mean change of improvement is 22% at post testing).

The last seven children showed some improvements in their crawling dimension of GMFM-88 was seen on items 38, 41, 44, 45, 48, 50, and 51 at post testing. Three children of them showed improvements on item 38 as they got a score from 0 or 1 to 3 as two spastic children of them as well as one child from the first subgroup who used rolling or crawling or hitching forward as a method of transfer from place to another before treatment, while their creeping ability is restricted. The third child with a moderate spasticity (level IV) also had limited ability on creeping on pre-testing. After treatment he became able to creep independently. Remaining four of those seven children showed varying scores of improvements on item 48. Two children of them who are able to hitch forward 1.8 meter (6 inches) at pre-testing succeeded to crawl reciprocally at post-testing.

Of the remaining two children, one child was not cooperative and another child with a past history of tendon elongation surgery, who had a percentage mean

score of 81% on crawling dimension of GMFM at pre testing show no change between pre and post testing.

Statistically, the changes obtained in this dimension at the end of the therapy program were statistically significant.

On Standing Dimension:

According to study finding, post testing to standing dimension of GMFM showed the least percentage scores but a statistically significant deference after STBWS program. The standing mean change for all children was 5.60 that scored 10 on baseline assessment.

At post testing fourteen of fifteen children showed some improvements in standing dimension of GMFM-88. Two children of them showed obvious increase in standing dimension of GMFM-88 after treatment. They achieved a score from 2 to 3 on items 53, 54, and 55 for a male child; and a score from 2 to 3 on item 53 for the female child. Both of them got a score from 0 to 2 on item 56: both children became able to stand with arms free for seven seconds. Figure 7: show a male child became able to stand with arms free for seven seconds after treatment. Five children of the subgroup had essential ability to pull to stand, four children of them got a score from 1 to 2 on item 53; and one child from the same four children gets a score from 2 to 3 on items 54, and 55; and the third child from the same four children got a score from 0 to 1 on item 55. At post testing all the five children got a score from 0 to 1 on item 56 in which they become able to stand with arm free < 3 seconds.

One obese female child with a past history of tendon elongation surgery demonstrated improvements in standing dimension of GMFM after treatment, as she got a score from 1 to 2 on item 53: she became able to stand with one hand support.

Two severe spastic children despite their low gross motor ability in sitting and crawling abilities, both children succeeded to show obvious improvements in their standing ability at the end of training program, but their standing ability was still relatively low. One child of them got a score from 0 to 1 on item 53, and the second child got a score from 2 to 3 on item 52 of GMFM-88.

The remaining four children showed little improvement in standing dimension of GMFM-88 after treatment, three children of them succeeded to get a score from 0 to 1 on item 53. And the fourth is easily fatigued female child got a score from 0 to 1 on item 52.

The only one very spastic child (level IV) who has muscle shortening in his upper extremities flexors, failed to show improvements in standing dimension of GMFM-88 at post testing.

Statistically, the changes obtained in this dimension at the end of the therapy program were statistically significant.

Although one cannot draw any conclusions based on this information, the fifteen children after STBWS program displayed normal position of trunk over stand. The trunk became more upright over stance instead of relatively flexed. They could stand with better balance and for longer on their supported lower legs. Two children sustained erect upright standing while supporting from their pelvis and other eight children sustained erect upright standing while supporting from knees and sometimes

below the knee level by the therapist hands and one spastic child of them who had low gross motor ability became able to stand upright while only supported from the more affected limb at knee level. The remaining five children became able to stand while supported at last third of their legs due to knee joint stability only with the therapist's fingers.



Figure 10: show a child became able to stand with arms free for seven seconds after

Treatment

Family Report

After a specific period of intensive stretching exercise and STBWS children parents reported that their child became able to do one or more of these: sit with feet in front with a wider abduction, flex one leg at hip and knee toward his chest from sitting with feet in front, sit with crossed legs, more straight legs (i.e. decrease hip and knee flexion during weight bearing position), decrease toe standing, decrease deformity of external rotation toward neutral position, sustain prone sleeping, rolling, creep, sit with arm free on high bench, on the floor: attain sitting on the wheel chair and vice versa, crawl reciprocally forward instead of hitching, hitching, kneeling walk, sustain own weight on legs on bench, desire to stand by get up from the chair and try to take away from chair then try to stand, get up from the wall and try to take away from wall then try to stand free, desire and repetitive trying to stand up from the floor, prolonged standing anteriorly and posteriorly against wall, cruise against wall, and better outdoor walking. Also parents report that their child is able to do the ADL tasks equal to their peers in every task perform on the floor. Observations of the improvement of motor abilities during the 21 weeks of STBWS program for each child are showed in appendix 7.

Chapter 5

Discussion

5.1 Changes on Dimension A, B, C, and D of Score of GMFM after STBWS treatment

There was an increase in gross motor function's dimension A, B, C, and D of GMFM-88 as well as goal (standing) total score at post test. The goal total score mean change for all children was 7.93 that scored 53.13 on baseline assessment.

On Lying and Rolling Dimension:

Dimension A (lying & Rolling) tend to show the lowest mean change. The lack of significant changes in dimension A was probably attributable to the children's nearly full scores on this dimension at the baseline.

The researcher thought that the problem behind lying and rolling scores reduction in the two mentioned children with spastic diplegia (level III) at pre-test may be spasticity in their lower extremities as they had dynamic sitting balance at pre testing. The magnitude of change in these two children may be due to the effect of regular full stretching exercise of adductors, flexors, hamstrings, and calf muscles that may decrease spasticity and as a result of increasing range of motion on their lower extremities. In addition, it may relay to the effects of STBWS treatment that may also play a role on reducing muscle tone on spastic muscles on lower body through prolonged static stretching during prolonged static upright standing and via weight bearing. In the same time, STBWS treatment may also activate agonist and antagonist co-contraction in the upper and lower body; as they sustain body weight and through active involvement of the child in supporting his/or her body against gravity during

upright standing for prolonged period of time and maximum repetition that lead to these improvements in lying function.

The improvements in third male spastic child at (level IV) who had the least percentage score in the lying and rolling dimension of GMFM at pre-test. The improvements in this child's rolling ability may be due to both stretching exercise and STBWS treatment stretching effect via weight bearing which may play a role in elongation of the spastic muscles then stimulate their contractions and as a result of decreasing spasticity and increasing muscle strength in the lower extremities that may activate brain cells to increase child muscle power to do these tasks independently.

The fourth child who had shortening in the flexors muscles of his upper extremities, the improvements of upper extremities function may be due to once or twice stretching exercise to upper extremities. Or they may as a result of the effect of STBWS treatment conjunct with regular stretching exercise on the child's lower extremities that may improve the child's gross motor abilities that may reflect positively on his upper extremities function. Or it may be due to strengthening and activation of transverse abdominous muscles during trunk-pelvic control training in upright standing.

On Sitting Dimension

The dimension that showed the largest increase of mean change was the dimension B (Sitting).

The improvements in the first five children may be due to these children take a benefit from STBWS treatment that may improve uprightness in sitting and standing that may lead to increase their muscles strengths and power, sitting control,

coordination, sitting balance, endurance, ... etc. to the level that needed for sitting function maturation; as the nature of STBWS treatment is an intensive antigravity training during supported upright standing for prolonged period of time and maximum repetition needed for maturation of sitting function in these five children;

Possible explanations to the reduction in the sitting dimension scores in six children of the second improved group at pre testing may be referred to high spasticity in their lower extremities. The improvements in these six children at post testing may be due to the effect of regular stretching exercise on spasticity and/or may be due to the STBWS treatment both static stretching via weight bearing during upright standing and its effect on spasticity reduction and/or STBWS against gravity. This may minimized or normalize the muscle tone and activate motor function in both upper body and lower body that may reflect positively on sitting position and function as well as the lower body;

And the only some improvements in the spastic male child (level IV) who had a problem in spasticity as well as he had no dynamic sitting balance may be due to this child received less number of sessions and therefore less amount of STBWS treatment. This may affect his magnitude of recovery in dynamic sitting and/or may be due to shortening in his upper extremities flexors that limit using his hands to assume sitting form side lying position, move from sitting into a variety positions, and to perform specific task while maintaining sitting position.

The last three children who had full scores in sitting dimension of GMFM at both testing periods, meaning they may be unable to be assessed for further improvement by using STBWS treatment.

On Crawling and Kneeling Dimension

Thirteen of fifteen children showed improvements in all items of this dimension.

Possible explanations of the main problem in this dimension in the three children of the first subgroup who they were able to hitch or move forward in four points on baseline assessment is concentrate on spasticity and ROM in addition to relatively low motor ability problems. These improvements in those three children may be due to they take a benefited from regular full stretching exercise of adductors, flexors, hamstrings, and calf muscles. And/or it may from STBWS treatment as it works as a prolonged static stretching during prolonged upright standing position that may also play a role in tone reduction in these muscles allowing improved RO M. For example: from prone position: creep forward 1.8 meters (6 inch) and crawl reciprocally instead of hitching. In addition, it may be due to increased in the antigravity muscles power and function of the lower limbs post STBWS treatment that may enable the improvements in antigravity crawling tasks e.g. on items 48, and 51;

Moreover, the improvements in two children of the second subgroup who got low gross motor scores on their crawling percentage scores at pre-testing may be transferred to regular stretching exercise conjunct with STBWS treatment that may play a role in spasticity reduction as well as uprightness training by using STBWS treatment. This may improved their gross motor ability which is reflect positively on their abilities to creep, assume and maintain variations of four-points and high kneeling, and hitching.

The expectations about the improvements in the last seven children who showed some improvements in their crawling dimension of GMFM-88 may be due to regular full stretching exercise as well as/or STBWS treatment prolonged static stretching through upright standing and weight bearing on both lower extremities. This may lead to decreased muscle tone on lower extremities and improved ROM. In addition, it may be due to the STBWS treatment and their effects on antigravity muscles that may play a role in improvements of gross motor function on creeping and crawling dimension by increasing ROM and muscle power on upper and lower body in those children; as their creeping ability restriction may be referred to their spasticity factor.

Two children, one child is not cooperative and another child with a past history of tendon elongation surgery who had a percentage score of 81% on crawling dimension of GMFM at pre testing showed no change between pre and post testing.

On Standing Dimension:

At post testing fourteen of fifteen children showed some improvements in standing dimension of GMFM-88.

The only one very spastic child (level IV) with muscle shortening in his upper extremities muscle flexors fails to show improvements in standing dimension of GMFM-88 at post testing. This may be due to this child received less number of sessions and therefore less amount of STBWS treatment and/or may be due to shortening in his upper extremities flexors lead to inability to use spastic arms for support. This may affect his magnitude of recovery in standing as well as the gross motor functions in the previous dimensions.

Improvement in standing ability as well as gross motor ability may be revealed to STBWS treatment with conjunct to regular stretching exercise program.

As mentioned previously, the nature of STBWS treatment, as it is a technique that introduces a maximum repetition of prolonged and intensive upright training in a supported upright standing position. This may play a role in activation of brain cells through plasticity, and/or motor learning and increase communication between sensory stimulation and motor response, and gives the child a chance to active participation during supported upright standing. Antigravity upright standing may normalize muscles tone and increase muscles strength in agonist and antagonist of the upper and supported lower body through prolonged static standing that also works as a static stretching during supported upright standing. This permit active participation of the child to support his/or her body weight and balance against gravity in erect upright standing posture against gravity as much as possible.

In the same time, STBWS treatment may enable building up upright posture by increase muscle strength and power in the lower extremities through prolonged body weight bearing on the stretched spastic muscles during supported upright standing with/or without sufficient support. These permit the child to active weight bearing as much as possible during supported upright standing for prolonged period of time and maximum repetition necessary to induce brain cell activation. The ROM also may facilitated by regular full stretching exercise on mat that may help in elongation of the spastic muscles and soft tissue of lower extremities that may lead to reduce spasticity or muscle tone then maintained and functioned via weight bearing during and postural control during upright posture through practice STBWS treatment.

The fifteen children failed to show further improvements in standing dimension of GMFM-88 by using STBWS treatment. Because the children have gaps in their gross motor ability preceded the standing as well as the standing ability and the total mean of treatment session was 30 ± 8 and this training period may be needed to filling out these gaps but may be not sufficient to induce independency or reach the maturity in standing ability.

All children improved their functional ability on dimensions A, B, C, and D of GMFM with no children showing a negative change.

The training effect was larger as the intensity of the program is increased.

The STBWS therapy program in this study can be said to be quite intensive and lengthy, and the children showed improvements.

5.2 Discussion of the Overall Study:

The aim of the study was to identify improvement in standing ability in children with spastic diplegia CP who are nonambulant after 21 weeks of standing training with manual BWS intervention conjunct with regular stretching exercises.

Building up upright standing may need before to filling out gaps in gross motor functions in the previous dimensions. After STBWS treatment, the children showed improvements in antigravity tasks in standing as well as all gross motor functions preceded it, for example static sitting maturation after STBWS treatment in some children who cannot able to sit with arm free transferred to better improvements in dynamic sitting in most children, attain high kneeling, kneeling walk, pull to stand, maintain standing arm free in addition to rolling and creeping maturity in children with very low gross motor ability as well as spastic children, ... etc. Possible expectation about these improvements may revealed to STBWS treatment stretching effect via weight bearing and STBWS treatment effect in improving muscle length and strength, coordination, motor control, balance, endurance, ...etc.

As the nature of STBWS treatment is an intensive upright training gives the child an opportunity to experience, gradual active participation in supporting his or her body weight against gravity, sustain limb loading, and keep his or her balance through supported upright standing for prolonged period and maximum repetition necessary to maximize motor learning and plasticity. All of these adaptive standing environments may work as an efferent neuron to stimulate function in the brain cells and then matures more rapidly through use to promote motor response or maturation.

As the study sample is moderate to severe spastic therefore it is necessary to administer a regular stretching exercise program. After treatment, the children

demonstrate improvements in their ROM reflect positively in their performance in gross motor functions for example, some children who had most of dynamic balance in upright sitting and kneeling as well as hitches or crawl reciprocally before treatment, after treatment they may take a benefit from the stretching effects either from administered regular full stretching exercise and/or STBWS treatment stretching effects via weight bearing that may play a role in reducing spasticity and improving ROM as the children become able to creep, crawl reciprocally instead of hitching, crawl up and down, half kneeling, kneeling walk lift/right side sitting, rolling, ...etc that may facilitate building standing;

Levitt (2010) reported that 'methods for strengthening, stretching short muscles, decreasing hypertonus/spasticity and mobilizing joint in lying may show results, but will not necessarily transfer to functions in other channels of development against gravity' (p. 68). Therefore, the effects of administered stretching exercise on mat relay only to facilitate building of standing but not necessarily acquisition of standing function.

The improvements in the total goal score as well as standing dimension of GMFM-88 in children was significant. Wang et al (2006) have stated in their study on responsiveness of the GMFM that an increase of 3.7% would be clinically meaningful. Whereas total goal score of gross motor function showed a significant increase of 7.93 %, dimension D of the GMFM showed a significant increase of 5.6% with statistical significance. These findings are similar to the finding reviewed by Palisano (2004) that treadmill training with partial body weight support has been successful in improving performance on both standing and walking sections of GMFM in a group of nonambulatory children with CP (Schindl, Forstner, Kern, & Hesse, 2000). Improved GMFM scores (Cherng et al 2007). Because current study

use standing task training with nonambulant CP who could not sustain own weight on their legs; there is no direct comparison of these results can be made with the findings of previous studies.

Some power of this study should be taken into consideration as the previous studies focus only in walking training on ambulant CP children who had build standing posture, but this trial of STBWS intervention was the only study focus on nonambulant spastic diplegic CP children who could not maintain independent standing.

Conclusion

This study provided evidence that STBWS treatment enhance the improvement in the standing ability in addition to filling gaps in the previous dimension of gross motor function in children with spastic diplegic CP (level III & IV), indicating that STBWS treatment is a suitable management for improving standing ability.

Current evidence suggests that the use of STBWS treatment as described in this study was effective in improving the standing function of children with spastic diplegia CP. However, the improvements in standing did not reach the functional level of normal children.

Limitations

There are several limitations of the present study. First, the difficulties of sample selection in choosing diplegic CP children as Bobath (1980) reported that 'the spastic quadriplegia and spastic diplegia have many features in common, and sometimes it is not easy to decide whether the child has diplegia or quadriplegia' (p. 46). Second, the nature of training is physically demand for both children and trainers.

Finally, the amount and level of BWS was determined individually according to therapist clinical decision.

Future studies should focus on children with young age to avoid time complications of extreme spasticity, deformity, and to avoid sever crouched knees due to overstretched or lengthened heel cords after heel cord release procedures. In addition, to reach further improvements or maturation in standing ability, therefore, the children may need for further STBWS intervention time or to address walking training as an advance task training to complete filling gaps in the standing.

Recommendation

This type of training needs trainers who have to be patient with their children. Determine the training parameters at which the STBWS treatment can be more effective. As yet there is no research to suggest how long the effects of STBWS treatment last, it could be useful to follow up the children of this study to document changes in physical functions or continue the STBWS treatment for further time to determine the maturity time of independent standing. Recommend to use of STBWS treatment during physical therapy sessions and during standing and gait training for children with spastic diplegic CP. Use STBWS treatment as part of the home program. Design STBWS treatment educated-home training program administered to the CP children via their parents. Physiotherapy should be shifted from traditional to goal/task oriented approaches, based on principles of motor learning, strength and fitness training in Gaza Strip. Expand the experimental rehabilitation research especially in locomotor training with BWS in my country Palestine.

Suggestions

Suggest more studies about the issue of using STBWS treatment. Apply STBWS treatment for children with different types of CP to improve the standing. Design a research proposal to study the effect of STBWS treatment on standing of children with CP when combined with other treatment modalities.

Summary points:

- Prolonged and intensive STBWS treatment conjunct with full stretching exercise can improve standing ability in addition to filling gaps in the previous dimension of gross motor function in nonambulant spastic diplegia CP children who could not maintain independent standing.
- The STBWS treatment is a simple safe technique with a wide range of benefits and easily administered by caregiver to their children at homes.

Reference

1. Ashworth, B. (1964). *Preliminary trial of carisoprodal in multiple sclerosis*. Practitioner, 192, 31.
2. Baird, H.W., & Gordon, E.C. (1983). *Neurological evaluation of infants and children*. London: Spastics International Medical Publications, William Heinemann Medical Books.
3. Baker, R.C. (Ed.). (2001). *Pediatric primary care: Well-child care*. Philadelphia: Lippincott Williams and Wilkins.
4. Barbeau, H., & Visintin, M. (2003). Optimal outcomes obtained with body-weight support combined with treadmill training in stroke subjects. *Arch. Phys. Med. Rehabil.*, 84(10), 1458-65.
5. Begnoche, D.M., & Pitetti, K.H. (2007). Effects of traditional treatment and partial body weight treadmill training on the motor skills of children with spastic cerebral palsy. A pilot study. *Pediatr. Phys. Ther.*, 19(1), 11-19.
6. Blundell, S.W., Shepherd, R.B., Dean, C.M., & Adams, R.D. (2003). Functional strength training in cerebral palsy: a pilot study of a group circuit training class for children aged 4-8 years. *Clin. Rehabil.*, 17, 48-57.
7. Bobath, K. (1980). *A neurophysical basis for the treatment of cerebral palsy*. Mac Keith Press, London.
8. Bodkin, A.W., Baxter, R.S., & Heriza, C.B. (2003). Treadmill training for an infant born preterm with a grade III intraventricular hemorrhage. *Phys. Ther.*, 82, 1107-18.
9. Borggraefe, I., Klaiber, M., Schuler, T., Warken, B., Schroeder, S.A., & Heinen, F. (2010). Robotic-assisted treadmill therapy improves walking and standing performance in children and adolescents with cerebral palsy. *Eur. J. Paediatr.*

Neurol., ISSN 1090-3798.

10. Borggraefe, I., Meyer-Heim, A., Kumar, A., Schaefer, J.S., Berweck, S., & Heinen, F. (2008). Improved gait parameters after robotic-assisted locomotor treadmill therapy in a 6-year-old child with cerebral palsy. *Mov. Disord.*, 23, 280-283.
11. Campbell, S.K. (1999). *Decision making in pediatric neurologic physical therapy*. Philadelphia: Churchill Livingstone.
12. Carr, J., & Sheoherd, R. (1998). *Neurological rehabilitation*. Oxford: Butterworth & Heinemann.
13. Carreiro, J. (2003). *An osteopathic approach to children*. London: Churchill Livingstone.
14. Cernak, K., Stevens, V., Price, R., & Shumway-Cook, A. (2008). Locomotor training using bodyweight support on a treadmill in conjunction with ongoing physical therapy in a child with severe cerebellar ataxia. *Phys. Ther.*, 88, 88–97.
15. Chan, N.N.C., Smith, A.W., & Lo, S.K. (2004). Efficacy of neuromuscular electrical stimulation in improving ankle kinetics during walking in children with cerebral palsy. *Hong Kong Physiother. J.*, 22, 50-56.
16. Cherng, R.J., Liu, C.F., Lau, T.W., & Hong, R.B. (2007). Effect of treadmill training with body weight support on gait and gross motor function in children with spastic cerebral palsy. *Am J Phys Med Rehabil*, 86 (7), 548–555.
17. Chesed, Y. (2003). *Spirit magazine*. (Vol. II). New York: Yedei Chesed Inc.
18. Connolly, K.J., & Forssberg, H. (Ed.). (1997). *Neurophysiology and neuropsychology of motor development*. London: MacKeith Press.
19. Connolly, B.H., & Patricia, C.M. (2005). *Therapeutic exercise in developmental disabilities*. (3rd ed.). USA: SLACK Incorporated.

20. Day, J.A., Fox, E.J., Lowe, J., Swales, H.B., & Behrman, A.L. (2004). Locomotor training with partial body weight support on a treadmill in a nonambulatory child with spastic tetraplegic cerebral palsy: A case report. *Pediatr. Phys. Ther.*, 16(2), 106-113.
21. Dobkin, B.H. (Ed.). (2003). *The clinical science of neurologic rehabilitation*. (2nd ed.). Oxford: Oxford University Press.
22. Dodd, K.J., & Foley, S. (2007). Partial body-weight supported treadmill training can improve walking in children with cerebral palsy: A clinical controlled trial. *Dev. Med. Child. Neurol.*, 49(2), 101-105.
23. Dunn, R.B., Walter, J.S., Lucero, Y., Weaver, F., Langbein, E., Fehr, L., Johnson, P., & Riedy, L. (1998). Follow-up assessment of standing mobility device users. *Assistive Technol*, 10(2), 48-93.
24. Effgen, S.K., & McEwen, I.R. (2007). *Review of selected physical therapy interventions for school age children with disabilities*. Center on Personnel Studies in Special Education.
25. *Evaluation the effectiveness of community base rehabilitation services provided to clients with cerebral palsy in Gaza government*. Gaza: Islamic University.
26. Fedrizzi, E., Avanzini, G., & Crenna, P. (Ed.). (1994). *Motor development in children*. London: John Libbey.
27. Field-Fote, E.C., Lindley, S.D., & Sherman, A.L. (2005). Locomotor training approaches for individuals with spinal cord injury: A preliminary report of walking-related outcomes. *J. Neurol. Phys. Ther.*, 29(3), 127-137.
28. Fulk, G.D. (2005). Locomotor training with body weight support after stroke: The effect of different training parameters. *J. Neurol. Phys. Ther.*, 29, 34-42.
29. Gage, J.R. (1991). *Gait analysis in cerebral palsy*. London: Mac Keith Press.

30. Gage, J., Schwartz, M., Koop, S., & Novacheck, T. (2009). *The identification and treatment of gait problems in cerebral palsy*. (2nd ed.). London: John Wiley and Sons.
31. Gelber, D.A., & Jeffery D.R. (Ed.). (2002). *Clinical evaluation and management of spasticity*. Totawa: Humana Press.
32. Ghanem, N.M. (2008). *Evaluation the effectiveness of community base rehabilitation services provided to clients with cerebral palsy in Gaza government*. Gaza: Islamic University.
33. Green, E.M., Mulcahy, C.M., Pountney, T.E., & Ablett, R.E. (1993). The Chailey standing support for children and young adults with motor impairment: A developmental approach. *Br J Occup Ther*, 56(1),13–18.
34. Henderson, R., Kiaralla, J., Abbas, A., & Stevenson, R. (2004). Predicting low bone density in children and young adult with quadriplegic cerebral palsy. *Dev. Med. Child. Neurol.*, 46, 416-419.
35. Hinchcliffe, A. (2007). *Children with cerebral palsy: A manual for therapists, parents and community workers*. (2nd ed.). London: SAGE.
36. Jane, E.C. (2003). *An osteopathic approach to children*. London: Elsevier Health Sciences.
37. Kalverboer, A.F., Hopkins, B., & Geuze, R.H. (Ed.). (1993). *Motor development in early and later childhood: Longitudinal approaches*. Cambridge: Cambridge University Press.
38. Kralj, A.R., & Bajd, T. (1989). *Functional electrical stimulation: Standing and walking after spinal cord injury*. Boca Raton(Florida): CRC Press Inc.
39. Kyllerman, M., Bager, B., & Bensch, J. (1982). Dyskinetic cerebral palsy: Clinical categories associated neurological abnormalities and incidences. *Acta. Paediatr.*,

71, 551-558.

40. Latash, M.L., & Levin, M.F. (Ed.). (2004). *Progress in motor control: Effects of age, disorder, and rehabilitation*. (Vol. III). Human Kinetics; Urbana.
41. Latash, M.L. (2008). *Neurophysiological basis of movement*. (2nd ed.). USA (Champaign): Human Kinetics.
42. Levitt, S. (2004). *Treatment of cerebral palsy and motor delay*. (4th ed.). Oxford: Wiley-Blackwell.
43. Levitt, S. (2010). *Treatment of cerebral palsy and motor delay*, (5th ed.). Oxford: John Wiley and Sons.
44. Lovell, W.W., Winter, R.B., Morrissy, R.T., Weinstein, S.L. (Ed.). (2001). *Lovell and Winter's pediatric orthopedics*. (5th ed.). Philadelphia: Williams and Wilkins.
45. Mayston, M. (2001). People with cerebral palsy: effects of and perspectives for therapy. *Neural Plast.*, 8(1-2), 51-69.
46. McNevin, N.H., Coraci, L., & Schafer, J. (2000). Gait in adolescent cerebral palsy: The effect of partial unweighting. *Arch. Phys. Med., Rehabil.*, 81, 525-8.
47. Medical Advisory Secretariat. (2005). Intrathecal baclofen pump for spasticity: an evidence-based analysis. *Ontario Health Technol Assess Series*, 5(7), 10-93.
48. Melillo, R., & Leisman, G. (2004). *Neurobehavioral disorders of childhood: An evolutionary perspective*. New York: Kluwer Academic.
49. Meyer-Heim, A., Ammann-Reiffer, C., Schmartz, A., Schäfer, J., Sennhauser, F.H., Heinen, F., Knecht, B., et al. (2009). Improvement of walking abilities after robotic-assisted locomotion training in children with cerebral palsy. *Arch. Dis. Child*, 94 (8), 615-620.
50. Meyer-Heim, A., Borggraefe, I., Ammann-Reiffer, C., Berweck, St., Sennhauser, F.H., Colombo, G., et al. (2007). Feasibility of robotic-assisted locomotor training

- in children with central gait impairment. *Dev. Med. Child Neurol.*, 49, 900-906.
51. Miller, F., & Bacharach, S.J. (1995). *Cerebral palsy: A complete guide for caregiving*. Baltimore: The John Hopkins University Press.
52. Mutlu, A., Livanelioglu, A., & Gunel, M.K. (2008). Reliability of Ashworth and modified Ashworth scales in children with spastic cerebral palsy. *BMC Musculoskeletal Disorders*, 9, 44.
53. Nasser, M. (1994). *Is withdrawal of physiotherapy during school holiday associated with a deterioration of motor skills in children with cerebral palsy?* England: University of Southampton, Rehabilitation Research Unit.
54. Oliver, J., & Middleditch, A. (1991). *Functional anatomy of the spine*. Oxford: Butterworth-Heinemann.
55. Palestinian Medical Relief Society. (2008). *Medical relief statistics report*. PMRS: Gaza.
56. Palisano, R. (Ed.). (2004). *Movement sciences: Transfer of knowledge into pediatric therapy practice*. Binghamton: Haworth press.
57. Palisano, R., Rosenbaum, P., Walter, S., Russell, D., Wood, E., & Galuppi, B. (2007). *Expanded and revised gross motor function classification system*. Canada: McMaster University.
58. Phillips, J.P., Sullivan, K.J., Burtner, P.A., Caprihan, A., Provost, B., & Bernitsky-Beddingfield, A. (2007). Ankle dorsiflexion fMRI in children with cerebral palsy undergoing intensive body-weight-supported treadmill training: A pilot study. *Dev. Med. Child Neurol.*, 49, 39–44.
59. Pin, T., Dyke, P., & Chan, M. (2006). The effectiveness of passive stretching in children with cerebral palsy. *Dev. Med. Child Neurol.*, 48(10), 855-862.
60. Provost, B., Dieruf, K., Burtner, P.A., Phillips, J.P., Bernitsky-Beddingfield, A.,

- Sullivan, K.J., et al. (2007). Endurance and gait in children with cerebral palsy after intensive body weight-supported treadmill training. *Pediatr. Phys. Ther.*, *19(1)*, 2-10.
61. Richards, C.L., Malouin, F., Dumas, F., Marcoux, S., Lepage, C., & Menier, C. (1997). Early and intensive treadmill locomotor training for young children with cerebral palsy: A feasibility study. *Pediatr. Phys. Ther.*, *9*, 158-165.
62. Roberts, T.D. (1995). *Understanding balance: The mechanics of posture and locomotion*. London: Chapman and Hall.
63. Russell, D.J., Rosenbaum, P.L., Gowland, C., Hardy, S., Lane, M., Plews, N., et al. (1993). *Gross motor function measure manual*. (2nd ed.). Hamilton (Canada): McMaster University.
64. Schindl, M.R., Forstner, C., Kern, H., & Hesse, S. (2000). Treadmill training with partial body weight support in nonambulatory patients with cerebral palsy. *Arch Phys Med Rehabil*, *81*, 301-6.
65. Selzer, M.E., Cohen, L., Gage, F.H., Clarke, S., & Duncan, P.W. (Ed.). (2006). *Textbook of neural repair and rehabilitation*. (Vol. II). Cambridge: Cambridge University Press.
66. Shukrallha, A. (2004). *Prevention, early detection and management of childhood disabilities*. Cairo: Association for Health & Environmental Development.
67. Shumway-Cook, A. & Woollacott, M.H. (2007). *Motor control: Translating research into clinical practice*. (3rd ed.). Philadelphia (PA): Lippincott Williams & Wilkins.
68. Song, W.H., Sung, I.Y., Kim, Y.J., & Yoo, J.Y. (2003). Treadmill training with partial body weight support in children with cerebral palsy. *Arch. Phys. Med. Rehabil.*, *84 (9)*, E2.

69. Staheli, L.T. (Ed.). (2003). *Pediatric orthopedic secrets*. (2nd ed.). Philadelphia: Hanley and Belfus.
70. Stuber, W.A. (1992). Consideration related to weight-bearing programs in children with developmental disabilities. *Phys. Ther.*, 72(1), 35-40.
71. Stuber, W., DeJong, S., & Spady, K.L. (2005). Conditioning effects of partial body weight support treadmill training in children with cerebral palsy. *Pediatr. Phys. Ther.*, 17 (1), 78.
72. The Institution for Rehabilitation and Research. (2005). Locomotor Training At TIRR Using The Robomedica ® Body Weight Support System.
73. The University of New South Wales. (2006). *Standing, line of gravity at joints, postural sway and correction of perturbations*. Sydney: Research Center at UNSW.
74. Thompson, C.R., Figoni, S.F., Devocelle, H.A., Fifer-Moeller, T.M., Lockhart, T.L., & Lockhart, T.A. (2000). Effect of dynamic weight bearing on lower extremity bone mineral density in children with neuromuscular impairment. *Clin. Kinesiol.*, 54(1), 13-18.
75. Tremblay, F., Malouin, F., Richards, C.L., & Dumas, F. (1990). Effects of prolonged muscle stretch on reflex and voluntary muscle activation in children with spastic cerebral palsy. *Scand. J. Rehab. Med.*, 22, 171-180.
76. Turmusani, M. (2003). *Disabled people and economic needs in the developing world: A political perspective from Jordan*. Aldershot (UK): Ashgate.
77. Unnithan, V., Kenne, E., Logan, L., Collier, S., & Turk, M. (2006). The effect of partial body weight support on the oxygen cost of walking in children and adolescents with spastic cerebral palsy. *Pediatr. Exerc. Sci.*, (17), 11-21.
78. US Census Bureau. (2004). International Data Base.

79. Vignos, P., Wagner, M., & Karlinchak, B. (1996). Evaluation of a program for long-term treatment of Duchenne muscular dystrophy. *JBJS*, 78(12), 1844-1852.
80. Walter, J.S., Sola, P.G., Sacks, J., Lucero, Y., Langbein, E., & Weaver, F. (1999). Indication for a home standing program for individual with spinal cord injury. *J. SpinalCord Med.*, 22(3), 152-8.
81. Wang, H.Y., & Yang, Y.H. (2006). Evaluating the responsiveness of 2 versions of the gross motor function measure for children with cerebral palsy. *Arch. Phys. Med. Rehabil.*, 87, 51-6.
82. Werner, D. (1999). *Disabled village children: A guide for community health workers, rehabilitation workers, and families*, In: *Standing frames*. Palo Alto (CA): Hesperian Foundation.
83. Whedon, G.D. (1982). Changes in weightlessness in calcium metabolism and in the musculoskeletal system. *Physiol.*, 25(6), 541-4.
84. Willoughby, K.L., Dodd, K.J., Shields, N., & Foley, S. (2010). Efficacy of partial body weight-supported treadmill training compared with overground walking practice for children with cerebral palsy: A randomized controlled trial. *Arch. Phys. Med. Rehabil.*, 91(3), 333-9.
85. Yongqiang, L. (2008). *Robotic training for motor rehabilitation after complete spinal cord injury*. California Institute of Technology.

Appendix (1)

Ethical approval for research

بِسْمِ اللَّهِ الرَّحْمَنِ الرَّحِيمِ



الجامعة الإسلامية - غزة
The Islamic University - Gaza

هاتف داخلي: 1150

عمادة الدراسات العليا

الرقم: Ref/35/ع.م.ع.ج
1/9/2008
التاريخ: Date

الإخوة الأفاضل/ مؤسسة فلسطين المستقبل للشلل الدماغي حفظهم الله،
السلام عليكم ورحمة الله وبركاته،

الموضوع / تسهيل مهمة طالبة ماجستير

تهديكم عمادة الدراسات العليا أعطر تحياتها، وترجو من سيادتكم التكرم بتسهيل مهمة الطالبة/ رنا حبيب حسن عماد، برقم جامعي 220045741 المسجلة في برنامج الماجستير بكلية التربية تخصص الصحة النفسية المجتمعية-علوم التأهيل وذلك بهدف الحصول على المعلومات التي تساعد في إعداد دراستها للماجستير والتي بعنوان:

Standing Training with Manual Body Weight Support to Improve Standing in Nonamulant Children With Spastic Diplegic Cerebral Palsy in the Gaza Strip

والله ولي التوفيق،،،

عميد الدراسات العليا

د. زياد إبراهيم مقداد



صورة إلى:-
المكلف.

مسئول مهمة + تطبيق شهادة + الحصول على مطبوعات الخرافات 2008/7/15

بِسْمِ اللَّهِ الرَّحْمَنِ الرَّحِيمِ



الجامعة الإسلامية - غزة
The Islamic University - Gaza

هاتف داخلي: 1150

عمادة الدراسات العليا

الرقم:ج.ب.ع/35/Ref

1/9/2008

التاريخ:Date

الإخوة الأفاضل/ الإغاثة الطبية الفلسطينية للتأهيل المجتمعي
حفظهم الله،
السلام عليكم ورحمة الله وبركاته،

الموضوع/ تسهيل مهمة طالبة ماجستير

تهديكم عمادة الدراسات العليا أعطر تحياتها، وترجو من سيادتكم التكرم بتسهيل مهمة
الطالبة/ رنا حبيب حسن عماد، برقم جامعي 220045741 المسجلة في برنامج الماجستير
بكلية التربية تخصص الصحة النفسية المجتمعية-علوم التأهيل وذلك بهدف الحصول على
المعلومات التي تساعد في إعداد دراستها للماجستير والتي بعنوان:

**Standing Training with Manual Body Weight Support to
Improve Standing in Nonamulant Children With Spastic
Diplegic Cerebral Palsy in the Gaza Strip**

والله ولي التوفيق،،،

عميد الدراسات العليا

د. زياد إبراهيم مقداد



صورة إلى:-

الملك.

لتسهيل مهمة + تطبيق استشارة + الحصول على معلومات/الطلبات/35/Ref/2008

بِسْمِ اللَّهِ الرَّحْمَنِ الرَّحِيمِ



الجامعة الإسلامية - غزة
The Islamic University - Gaza

هاتف داخلي: 1150

عمادة الدراسات العليا

الرقم.....ج.م.ع/35/Ref

1/9/2008

التاريخ.....Date

الإخوة الأفاضل/ الجمعية الوطنية لتأهيل المعاقين حفظهم الله،
السلام عليكم ورحمة الله وبركاته،

الموضوع/ تسهيل مهمة طالبة ماجستير

تهديكم عمادة الدراسات العليا أعطر تحياتها، وترجو من سيادتكم التكرم بتسهيل مهمة
الطالبة/ رنا حبيب حسن عماد، برقم جامعي 220045741 المسجلة في برنامج الماجستير
بكلية التربية تخصص الصحة النفسية المجتمعية-علوم التأهيل وذلك بهدف الحصول على
المعلومات التي تساعد في إعداد دراستها للماجستير والتي بعنوان:

**Standing Training with Manual Body Weight Support to
Improve Standing in Nonamulant Children With Spastic
Diplegic Cerebral Palsy in the Gaza Strip**

والله ولي التوفيق،،،

عميد الدراسات العليا

د. زياد إبراهيم مقداد



صورة إلى:-
الرف. *

بتسهيل مهمة * تطبيق استشارة * الحصول على معلومات الخيارات * 800020

ص.ب. 108 الرمال غزة فلسطين هاتف Tel: +970 (8) 286 0700 فاكس fax: +970 (8) 286 0800
public@iugaza.edu.ps www.iugaza.edu.ps

Appendix (2)

Table 4: list of children participated in STBWS.

Code	Age	Sex	Other programs	Resident	NO of Sessions	General Note/Diagnosis
A	4	M	None	North	28	spastic diplegia
B	8	M	None	Gaza	29	spastic diplegia
C	7	M	None	Gaza	30	spastic diplegia
D	7	M	Yes Mobilizing and stretching exercises	Gaza	34	spastic diplegia
E	7	F	None	Gaza	36	spastic diplegia
F	4	M	None	Gaza	35	spastic diplegia
G	7	M	Yes Mobilizing and stretching exercises	Gaza	32	spastic diplegia
H	7	F	None	Middle	28	spastic diplegia, not cooperative
I	8	M	None	Middle	30	spastic diplegia
J	8	M	None	South	22	Less NO of sessions, have shortening in the upper extremities flexors
K	6	M	None	South	32	spastic diplegia
L	7	M	None	South	29	spastic diplegia
M	5	F	None	South	27	spastic diplegia
N	7	M	None	South	38	spastic diplegia
O	8	F	None	South	28	spastic diplegia with past history of tendon elongation surgery, obese child

Note: The standard deviation (± 8) of the session number contribute to two children; one child (-8) miss a number of session due to car accident to his father and another child (+8) who is the most keep to the STBWS therapeutic session.

Appendix (3) Parental Permission to Participate in Research

Research Title

Standing Training with Manual Body Weight Support to Improve Standing in Nonambulant Children with Spastic Diplegic Cerebral Palsy in the Gaza Strip

Researcher's Name: **Rana Habib Imad**

Islamic University

Parental Permission to Participate in Research

A. PURPOSE AND BACKGROUND

My name is Rana Imad. I am a (*graduate student/ Master of Rehabilitation Science*) at Islamic university.

I am conducting a research study about standing training with manual body weight support to improve standing in nonambulant children with spastic diplegic cerebral palsy in the Gaza Strip. I am inviting your child to take part in the research because he/she meet the inclusion criteria.

The purpose of the research; to improve standing ability in children with spastic diplegia CP who are nonambulant after 21 weeks of standing training with manual body weight support (STBWS) intervention conjunct with regular stretching exercises. Your child is being invited to participate in this study, as he/she is in the inclusion criteria that I am studying.

B. PROCEDURES

If you agree to let your child participate in this research study, the following will occur:

- Your child will be asked to follow instruction and take a test.
- This will take a regular STBWS intervention conjunct with regular stretching exercises as part of my scheduled curriculum.
- Your child will be invited to participate in after school.

The STBWS sessions will take place 45 minutes and 1:30 hour, three session per week for 21 weeks. The session will occur at home, and need the attendance of the child and the child's caregiver.

Research Title

Standing Training with Manual Body Weight Support to Improve Standing in Nonambulant Children with Spastic Diplegic Cerebral Palsy in the Gaza Strip

Researcher's Name: **Rana Habib Imad**

C. RISKS

There is a risk of falling down and physically fatigue during training using STBWS also may exposure to muscle fatigue and tearing during stretching exercise.

any real names or other identifiers in the written report. The researcher will also keep all data in a locked file cabinet in a secure location. Only the researcher will have access to the data.

the researcher will reduce these risks during a session by grasping the child securely during upright standing to prevent accidental falling down also the researcher will stretch the child's muscle gently to avoid muscle tearing and give the child frequent rest periods to reduce physically fatigue. If you will want to follow up in any way, get permission in this consent, and if the child indicates in any way that he/she does not want to participate, by crying or other behavior, we will stop immediately.

Research Title

E. DIRECT BENEFITS

There are no direct benefits for your child's participation in this project.

F. COSTS

There will be no costs for your child's participation in this project.

G. COMPENSATION

There will be no compensation for participation in this project.

H. ALTERNATIVES

The alternative is not to participate.

Research Title

**Standing Training with Manual Body Weight Support to Improve
Standing in Nonambulant Children with Spastic Diplegic Cerebral
Palsy in the Gaza Strip**

Researcher's Name: **Rana Habib Imad**

I. QUESTIONS

You have spoken with researcher's name about this study and have had your questions answered. If you have any further questions about the study, you may contact the researcher by calling (Mobile number: 0599599).

J. CONSENT

PARTICIPATION IN THIS RESEARCH STUDY IS VOLUNTARY. You are free to decline to have your child participate in this research study. You may withdraw your child's participation at any point without penalty. Your decision whether or not to participate in this research study will have no influence on your or your child's present or future status at University.

Child's Name _____

Date _____ Parent permission _____

Date _____

Researcher

Note: every word in the Parental Permission to Participate in Research procedure was translated orally into Arabic language by a researcher before the parents give permission to participate in STBWS program.

Appendix (4)

GROSS MOTOR FUNCTION MEASURE (GMFM) SCORE SHEET (GMFM-88 and GMFM-66 scoring)

Version 1.0

Child's Name: _____ ID #: _____

Assessment date: _____
year / month / day

Date of birth: _____
year / month / day

Chronological age: _____
years/months

GMFCS Level ¹

I II III IV V

Testing Conditions (eg, room, clothing, time, others present)

Evaluator's Name: _____

The GMFM is a standardized observational instrument designed and validated to measure change in gross motor function over time in children with cerebral palsy. The scoring key is meant to be a general guideline. However, most of the items have specific descriptors for each score. It is imperative that the guidelines contained in the manual be used for scoring each item.

SCORING KEY 0 = does not initiate
1 = initiates
2 = partially completes
3 = completes
NT = Not tested [used for the GMAE scoring*]

It is now important to differentiate a true score of "0" (child does not initiate) from an item which is Not Tested (NT) if you are interested in using the GMFM-66 Ability Estimator Software.

The GMFM-66 Gross Motor Ability Estimator (GMAE) software is available with the GMFM manual (2002). The advantage of the software is the conversion of the ordinal scale into an interval scale. This will allow for a more accurate estimate of the child's ability and provide a measure that is equally responsive to change across the spectrum of ability levels. Items that are used in the calculation of the GMFM-66 score are shaded and identified with an asterisk (). The GMFM-66 is only valid for use with children who have cerebral palsy.

Contact for Research Group:

Dianne Russell, *CanChild* Centre for Childhood Disability Research, McMaster University, Institute for Applied Health Sciences, McMaster University, 1400 Main St. W., Rm. 408, Hamilton, L8S 1C7
Tel: North America - 1 905 525-9140 Ext: 27850
Tel: All other countries - 001 905 525-9140 Ext: 27850
E-mail: canchild@mcmaster.ca Fax: 1 905 522-6095

Website: www.fhs.mcmaster.ca/canchild

¹ GMFCS level is a rating of severity of motor function. Definitions are found in Appendix I of the GMFM manual (2002).

Check (✓) the appropriate score: if an item is not tested (NT), circle the item number in the right column

Item	A: LYING & ROLLING	SCORE				NT
1.	SUP: HEAD IN MIDLINE: TURNS HEAD WITH EXTREMITIES SYMMETRICAL.....	0	1	2	3	1.
* 2.	SUP: BRINGS HANDS TO MIDLINE, FINGERS ONE WITH THE OTHER	0	1	2	3	2.
3.	SUP: LIFTS HEAD 45°	0	1	2	3	3.
4.	SUP: FLEXES R HIP AND KNEE THROUGH FULL RANGE	0	1	2	3	4.
5.	SUP: FLEXES L HIP AND KNEE THROUGH FULL RANGE	0	1	2	3	5.
* 6.	SUP: REACHES OUT WITH R ARM, HAND CROSSES MIDLINE TOWARD TOY	0	1	2	3	6.
* 7.	SUP: REACHES OUT WITH L ARM, HAND CROSSES MIDLINE TOWARD TOY.....	0	1	2	3	7.
8.	SUP: ROLLS TO PR OVER R SIDE	0	1	2	3	8.
9.	SUP: ROLLS TO PR OVER L SIDE	0	1	2	3	9.
* 10.	PR: LIFTS HEAD UPRIGHT	0	1	2	3	10.
11.	PR ON FOREARMS: LIFTS HEAD UPRIGHT, ELBOWS EXT., CHEST RAISED	0	1	2	3	11.
12.	PR ON FOREARMS: WEIGHT ON R FOREARM, FULLY EXTENDS OPPOSITE ARM FORWARD	0	1	2	3	12.
13.	PR ON FOREARMS: WEIGHT ON L FOREARM, FULLY EXTENDS OPPOSITE ARM FORWARD	0	1	2	3	13.
14.	PR: ROLLS TO SUP OVER R SIDE	0	1	2	3	14.
15.	PR: ROLLS TO SUP OVER L SIDE.....	0	1	2	3	15.
16.	PR: PIVOTS TO R 90° USING EXTREMITIES.....	0	1	2	3	16.
17.	PR: PIVOTS TO L 90° USING EXTREMITIES	0	1	2	3	17.

TOTAL DIMENSION A

Item	B: SITTING	SCORE				NT
* 18.	SUP, HANDS GRASPED BY EXAMINER: PULLS SELF TO SITTING WITH HEAD CONTROL	0	1	2	3	18.
19.	SUP: ROLLS TO R SIDE, ATTAINS SITTING.....	0	1	2	3	19.
20.	SUP: ROLLS TO L SIDE, ATTAINS SITTING	0	1	2	3	20.
* 21.	SIT ON MAT, SUPPORTED AT THORAX BY THERAPIST: LIFTS HEAD UPRIGHT, MAINTAINS 3 SECONDS	0	1	2	3	21.
* 22.	SIT ON MAT, SUPPORTED AT THORAX BY THERAPIST: LIFTS HEAD MIDLINE, MAINTAINS 10 SECONDS	0	1	2	3	22.
* 23.	SIT ON MAT, ARM(S) PROPPING: MAINTAINS, 5 SECONDS.....	0	1	2	3	23.
* 24.	SIT ON MAT: MAINTAINS, ARMS FREE, 3 SECONDS	0	1	2	3	24.
* 25.	SIT ON MAT WITH SMALL TOY IN FRONT: LEANS FORWARD, TOUCHES TOY, RE-ERECTS WITHOUT ARM PROPPING.....	0	1	2	3	25.
* 26.	SIT ON MAT: TOUCHES TOY PLACED 45° BEHIND CHILD'S R SIDE, RETURNS TO START.....	0	1	2	3	26.
* 27.	SIT ON MAT: TOUCHES TOY PLACED 45° BEHIND CHILD'S L SIDE, RETURNS TO START	0	1	2	3	27.
28.	R SIDE SIT: MAINTAINS, ARMS FREE, 5 SECONDS	0	1	2	3	28.
29.	L SIDE SIT: MAINTAINS, ARMS FREE, 5 SECONDS.....	0	1	2	3	29.
* 30.	SIT ON MAT: LOWERS TO PR WITH CONTROL.....	0	1	2	3	30.
* 31.	SIT ON MAT WITH FEET IN FRONT: ATTAINS 4 POINT OVER R SIDE	0	1	2	3	31.
* 32.	SIT ON MAT WITH FEET IN FRONT: ATTAINS 4 POINT OVER L SIDE	0	1	2	3	32.
33.	SIT ON MAT: PIVOTS 90°, WITHOUT ARMS ASSISTING	0	1	2	3	33.
* 34.	SIT ON BENCH: MAINTAINS, ARMS AND FEET FREE, 10 SECONDS	0	1	2	3	34.
* 35.	STD: ATTAINS SIT ON SMALL BENCH	0	1	2	3	35.
* 36.	ON THE FLOOR: ATTAINS SIT ON SMALL BENCH.....	0	1	2	3	36.
* 37.	ON THE FLOOR: ATTAINS SIT ON LARGE BENCH	0	1	2	3	37.

TOTAL DIMENSION B

Item	C: CRAWLING & KNEELING	SCORE				NT
38.	PR: CREEPS FORWARD 1.8m (6')	0	1	2	3	38.
* 39.	4 POINT: MAINTAINS, WEIGHT ON HANDS AND KNEES, 10 SECONDS	0	1	2	3	39.
* 40.	4 POINT: ATTAINS SIT ARMS FREE	0	1	2	3	40.
* 41.	PR: ATTAINS 4 POINT, WEIGHT ON HANDS AND KNEES	0	1	2	3	41.
* 42.	4 POINT: REACHES FORWARD WITH R ARM, HAND ABOVE SHOULDER LEVEL	0	1	2	3	42.
* 43.	4 POINT: REACHES FORWARD WITH L ARM, HAND ABOVE SHOULDER LEVEL	0	1	2	3	43.
* 44.	4 POINT: CRAWLS OR HITCHES FORWARD 1.8m (6')	0	1	2	3	44.
* 45.	4 POINT: CRAWLS RECIPROCALLY FORWARD 1.8m (6')	0	1	2	3	45.
* 46.	4 POINT: CRAWLS UP 4 STEPS ON HANDS AND KNEES/FEET	0	1	2	3	46.
47.	4 POINT: CRAWLS BACKWARDS DOWN 4 STEPS ON HANDS AND KNEES/FEET	0	1	2	3	47.
* 48.	SIT ON MAT: ATTAINS HIGH KN USING ARMS, MAINTAINS, ARMS FREE, 10 SECONDS	0	1	2	3	48.
49.	HIGH KN: ATTAINS HALF KN ON R KNEE USING ARMS, MAINTAINS, ARMS FREE, 10 SECONDS	0	1	2	3	49.
50.	HIGH KN: ATTAINS HALF KN ON L KNEE USING ARMS, MAINTAINS, ARMS FREE, 10 SECONDS	0	1	2	3	50.
* 51.	HIGH KN: KN WALKS FORWARD 10 STEPS, ARMS FREE	0	1	2	3	51.

TOTAL DIMENSION C

Item	D: STANDING	SCORE				NT
* 52.	ON THE FLOOR: PULLS TO STD AT LARGE BENCH	0	1	2	3	52.
* 53.	STD: MAINTAINS, ARMS FREE, 3 SECONDS	0	1	2	3	53.
* 54.	STD: HOLDING ON TO LARGE BENCH WITH ONE HAND, LIFTS R FOOT, 3 SECONDS	0	1	2	3	54.
* 55.	STD: HOLDING ON TO LARGE BENCH WITH ONE HAND, LIFTS L FOOT, 3 SECONDS	0	1	2	3	55.
* 56.	STD: MAINTAINS, ARMS FREE, 20 SECONDS	0	1	2	3	56.
* 57.	STD: LIFTS L FOOT, ARMS FREE, 10 SECONDS	0	1	2	3	57.
* 58.	STD: LIFTS R FOOT, ARMS FREE, 10 SECONDS	0	1	2	3	58.
* 59.	SIT ON SMALL BENCH: ATTAINS STD WITHOUT USING ARMS	0	1	2	3	59.
* 60.	HIGH KN: ATTAINS STD THROUGH HALF KN ON R KNEE, WITHOUT USING ARMS	0	1	2	3	60.
* 61.	HIGH KN: ATTAINS STD THROUGH HALF KN ON L KNEE, WITHOUT USING ARMS	0	1	2	3	61.
* 62.	STD: LOWERS TO SIT ON FLOOR WITH CONTROL, ARMS FREE	0	1	2	3	62.
* 63.	STD: ATTAINS SQUAT, ARMS FREE	0	1	2	3	63.
* 64.	STD: PICKS UP OBJECT FROM FLOOR, ARMS FREE, RETURNS TO STAND	0	1	2	3	64.

TOTAL DIMENSION D

Item	E: WALKING, RUNNING & JUMPING	SCORE				NT
* 65.	STD, 2 HANDS ON LARGE BENCH: CRUISES 5 STEPS TO R.....	0 <input type="checkbox"/>	1 <input type="checkbox"/>	2 <input type="checkbox"/>	3 <input type="checkbox"/>	65.
* 66.	STD, 2 HANDS ON LARGE BENCH: CRUISES 5 STEPS TO L.....	0 <input type="checkbox"/>	1 <input type="checkbox"/>	2 <input type="checkbox"/>	3 <input type="checkbox"/>	66.
* 67.	STD, 2 HANDS HELD: WALKS FORWARD 10 STEPS.....	0 <input type="checkbox"/>	1 <input type="checkbox"/>	2 <input type="checkbox"/>	3 <input type="checkbox"/>	67.
* 68.	STD, 1 HAND HELD: WALKS FORWARD 10 STEPS.....	0 <input type="checkbox"/>	1 <input type="checkbox"/>	2 <input type="checkbox"/>	3 <input type="checkbox"/>	68.
* 69.	STD: WALKS FORWARD 10 STEPS.....	0 <input type="checkbox"/>	1 <input type="checkbox"/>	2 <input type="checkbox"/>	3 <input type="checkbox"/>	69.
* 70.	STD: WALKS FORWARD 10 STEPS, STOPS, TURNS 180°, RETURNS.....	0 <input type="checkbox"/>	1 <input type="checkbox"/>	2 <input type="checkbox"/>	3 <input type="checkbox"/>	70.
* 71.	STD: WALKS BACKWARD 10 STEPS.....	0 <input type="checkbox"/>	1 <input type="checkbox"/>	2 <input type="checkbox"/>	3 <input type="checkbox"/>	71.
* 72.	STD: WALKS FORWARD 10 STEPS, CARRYING A LARGE OBJECT WITH 2 HANDS.....	0 <input type="checkbox"/>	1 <input type="checkbox"/>	2 <input type="checkbox"/>	3 <input type="checkbox"/>	72.
* 73.	STD: WALKS FORWARD 10 CONSECUTIVE STEPS BETWEEN PARALLEL LINES 20cm (8") APART.....	0 <input type="checkbox"/>	1 <input type="checkbox"/>	2 <input type="checkbox"/>	3 <input type="checkbox"/>	73.
* 74.	STD: WALKS FORWARD 10 CONSECUTIVE STEPS ON A STRAIGHT LINE 2cm (3/4") WIDE.....	0 <input type="checkbox"/>	1 <input type="checkbox"/>	2 <input type="checkbox"/>	3 <input type="checkbox"/>	74.
* 75.	STD: STEPS OVER STICK AT KNEE LEVEL, R FOOT LEADING.....	0 <input type="checkbox"/>	1 <input type="checkbox"/>	2 <input type="checkbox"/>	3 <input type="checkbox"/>	75.
* 76.	STD: STEPS OVER STICK AT KNEE LEVEL, L FOOT LEADING.....	0 <input type="checkbox"/>	1 <input type="checkbox"/>	2 <input type="checkbox"/>	3 <input type="checkbox"/>	76.
* 77.	STD: RUNS 4.5m (15'), STOPS & RETURNS.....	0 <input type="checkbox"/>	1 <input type="checkbox"/>	2 <input type="checkbox"/>	3 <input type="checkbox"/>	77.
* 78.	STD: KICKS BALL WITH R FOOT.....	0 <input type="checkbox"/>	1 <input type="checkbox"/>	2 <input type="checkbox"/>	3 <input type="checkbox"/>	78.
* 79.	STD: KICKS BALL WITH L FOOT.....	0 <input type="checkbox"/>	1 <input type="checkbox"/>	2 <input type="checkbox"/>	3 <input type="checkbox"/>	79.
* 80.	STD: JUMPS 30cm (12") HIGH, BOTH FEET SIMULTANEOUSLY.....	0 <input type="checkbox"/>	1 <input type="checkbox"/>	2 <input type="checkbox"/>	3 <input type="checkbox"/>	80.
* 81.	STD: JUMPS FORWARD 30 cm (12"), BOTH FEET SIMULTANEOUSLY.....	0 <input type="checkbox"/>	1 <input type="checkbox"/>	2 <input type="checkbox"/>	3 <input type="checkbox"/>	81.
* 82.	STD ON R FOOT: HOPS ON R FOOT 10 TIMES WITHIN A 60cm (24") CIRCLE.....	0 <input type="checkbox"/>	1 <input type="checkbox"/>	2 <input type="checkbox"/>	3 <input type="checkbox"/>	82.
* 83.	STD ON L FOOT: HOPS ON L FOOT 10 TIMES WITHIN A 60cm (24") CIRCLE.....	0 <input type="checkbox"/>	1 <input type="checkbox"/>	2 <input type="checkbox"/>	3 <input type="checkbox"/>	83.
* 84.	STD, HOLDING 1 RAIL: WALKS UP 4 STEPS, HOLDING 1 RAIL, ALTERNATING FEET.....	0 <input type="checkbox"/>	1 <input type="checkbox"/>	2 <input type="checkbox"/>	3 <input type="checkbox"/>	84.
* 85.	STD, HOLDING 1 RAIL: WALKS DOWN 4 STEPS, HOLDING 1 RAIL, ALTERNATING FEET.....	0 <input type="checkbox"/>	1 <input type="checkbox"/>	2 <input type="checkbox"/>	3 <input type="checkbox"/>	85.
* 86.	STD: WALKS UP 4 STEPS, ALTERNATING FEET.....	0 <input type="checkbox"/>	1 <input type="checkbox"/>	2 <input type="checkbox"/>	3 <input type="checkbox"/>	86.
* 87.	STD: WALKS DOWN 4 STEPS, ALTERNATING FEET.....	0 <input type="checkbox"/>	1 <input type="checkbox"/>	2 <input type="checkbox"/>	3 <input type="checkbox"/>	87.
* 88.	STD ON 15cm (6") STEP: JUMPS OFF, BOTH FEET SIMULTANEOUSLY.....	0 <input type="checkbox"/>	1 <input type="checkbox"/>	2 <input type="checkbox"/>	3 <input type="checkbox"/>	88.

TOTAL DIMENSION E

Was this assessment indicative of this child's "regular" performance? YES NO

COMMENTS:

GMFM RAW SUMMARY SCORE

DIMENSION	CALCULATION OF DIMENSION % SCORES			GOAL AREA <small>(indicated with ✓ check)</small>
A. Lying & Rolling	$\frac{\text{Total Dimension A}}{51}$	= $\frac{\quad}{51}$	$\times 100 = \quad\% \quad$	A. <input type="checkbox"/>
B. Sitting	$\frac{\text{Total Dimension B}}{60}$	= $\frac{\quad}{60}$	$\times 100 = \quad\% \quad$	B. <input type="checkbox"/>
C. Crawling & Kneeling	$\frac{\text{Total Dimension C}}{42}$	= $\frac{\quad}{42}$	$\times 100 = \quad\% \quad$	C. <input type="checkbox"/>
D. Standing	$\frac{\text{Total Dimension D}}{39}$	= $\frac{\quad}{39}$	$\times 100 = \quad\% \quad$	D. <input type="checkbox"/>
E. Walking, Running & Jumping	$\frac{\text{Total Dimension E}}{72}$	= $\frac{\quad}{72}$	$\times 100 = \quad\% \quad$	E. <input type="checkbox"/>
TOTAL SCORE = $\frac{\%A + \%B + \%C + \%D + \%E}{\text{Total \# of Dimensions}}$ $= \frac{\quad + \quad + \quad + \quad + \quad}{5} = \frac{\quad}{5} = \quad\%$				
GOAL TOTAL SCORE = $\frac{\text{Sum of \% scores for each dimension identified as a goal area}}{\# \text{ of Goal areas}}$ $= \frac{\quad}{\quad} = \quad\%$				

GMFM-66 Gross Motor Ability Estimator Score ¹

GMFM-66 Score = _____ to _____
95% Confidence Intervals

previous GMFM-66 Score = _____ to _____
95% Confidence Intervals

change in GMFM-66 = _____

¹ from the Gross Motor Ability Estimator (GMAE) Software

TESTING WITH AIDS/ORTHOSES

Indicate below with a check (✓) which aid/orthosis was used and what dimension it was first applied. (There may be more than one).

AID	DIMENSION	ORTHOSES	DIMENSION
Rollator/Pusher.....	<input type="checkbox"/> _____	Hip Control.....	<input type="checkbox"/> _____
Walker.....	<input type="checkbox"/> _____	Knee Control.....	<input type="checkbox"/> _____
H Frame Crutches.....	<input type="checkbox"/> _____	Ankle-Foot Control.....	<input type="checkbox"/> _____
Crutches.....	<input type="checkbox"/> _____	Foot Control.....	<input type="checkbox"/> _____
Quad Cane.....	<input type="checkbox"/> _____	Shoes.....	<input type="checkbox"/> _____
Cane.....	<input type="checkbox"/> _____	None.....	<input type="checkbox"/> _____
None.....	<input type="checkbox"/> _____	Other	<input type="checkbox"/> _____
Other	<input type="checkbox"/> _____	(please specify)	
(please specify)			

RAW SUMMARY SCORE USING AIDS/ORTHOSES

DIMENSION	CALCULATION OF DIMENSION % SCORES			GOAL AREA <small>(indicated with ✓ check)</small>
F. Lying & Rolling	$\frac{\text{Total Dimension A}}{51} = \frac{51}{51} \times 100 = \underline{\hspace{2cm}} \%$			A. <input type="checkbox"/>
G. Sitting	$\frac{\text{Total Dimension B}}{60} = \frac{60}{60} \times 100 = \underline{\hspace{2cm}} \%$			B. <input type="checkbox"/>
H. Crawling & Kneeling	$\frac{\text{Total Dimension C}}{42} = \frac{42}{42} \times 100 = \underline{\hspace{2cm}} \%$			C. <input type="checkbox"/>
I. Standing	$\frac{\text{Total Dimension D}}{39} = \frac{39}{39} \times 100 = \underline{\hspace{2cm}} \%$			D. <input type="checkbox"/>
J. Walking, Running & Jumping	$\frac{\text{Total Dimension E}}{72} = \frac{72}{72} \times 100 = \underline{\hspace{2cm}} \%$			E. <input type="checkbox"/>
TOTAL SCORE =	$\frac{\%A + \%B + \%C + \%D + \%E}{\text{Total \# of Dimensions}}$			
	$= \frac{\quad + \quad + \quad + \quad + \quad}{5} = \frac{\quad}{5} = \underline{\hspace{2cm}} \%$			
GOAL TOTAL SCORE =	$\frac{\text{Sum of \% scores for each dimension identified as a goal area}}{\text{\# of Goal areas}}$			
	$= \underline{\hspace{2cm}} = \underline{\hspace{2cm}} \%$			

GMFM-66 Gross Motor Ability Estimator Score ¹

GMFM-66 Score = _____ to _____
95% Confidence Intervals

previous GMFM-66 Score = _____ to _____
95% Confidence Intervals

change in GMFM-66 = _____

¹ from the Gross Motor Ability Estimator (GMAE) Software

Appendix (5)

Gross Motor Function Classification System (Palisano, 2007) and Prediction Outcomes (Gage, 2009) p. 152.

Table 5: expected functional abilities for children aged 6 to 12 years, according to the Gross Motor Function Classification System (GMFCS)	
GMFCS level	Descriptive
I	Walk without restrictions; limitations in more advanced gross motor skills.
II	Walk without assistive devices; limitations in walking outdoors and in the community.
III	Walk with handheld assistive mobility devices; limitations in walking outdoors and in the community.
IV	Self-mobility with limitation; children are transported or use power mobility outdoors and in the community.
V	Self-mobility is severely limited even with the use of assistive technology.

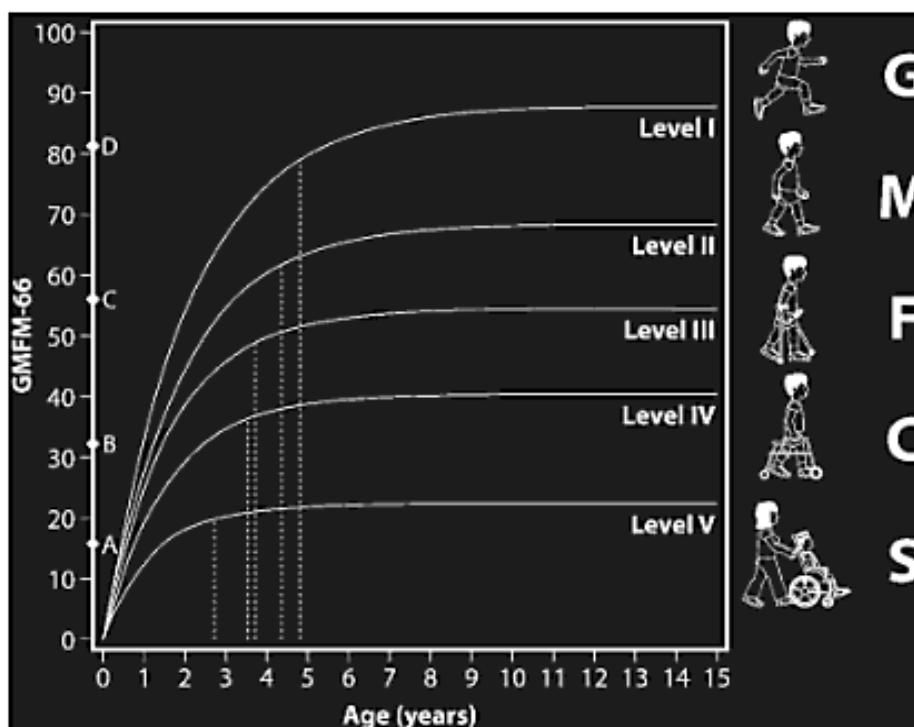

Figure 11: prediction of outcomes.

Appendix (6)

Ashworth Scale, Gelber and Jeffery (2002), p. 31

1. No increase in muscle tone.
2. Slight increase in tone giving a “catch” when affected part is moved in flexion or extension.
3. More marked increase in tone but affected part is easily flexed.
4. Considerable increase in tone; passive movement difficult.
5. Affected part is rigid in flexion or extension.

Appendix (7)

Table 6: observations were done by both the parents and the trainer of improvements of motor performance of function during 21 weeks of STBWS program for each child.

Code	GMFCS	Observation of progression of motor during 21 weeks of STBWS program
A	IV	sustain prone sleeping, hitching
B	IV	reciprocally forward instead of hitching, try to stand from floor, prolonged standing anteriorly and posteriorly against wall, better outdoor walking
C	III	more straight legs, decrease toe standing, sit with arm free on high bench, on the floor: attain sitting on the wheel chair and vice versa, prolonged standing anteriorly and posteriorly against wall
D	III	sit with feet in front with a wider abduction, flex one leg at hip and knee toward his chest from sitting with feet in front, sit with crossed legs, more straight legs, decrease toe standing, on the floor: attain sitting on the wheel chair and vice versa, crawl reciprocally forward instead of hitching, prolonged standing anteriorly and posteriorly against wall, cruise against wall, and better outdoor walking
E	III	more straight legs, decrease toe standing, decrease deformity of external rotation toward neutral position, on the floor: attain sitting on the wheel chair and vice versa, kneeling walk, prolonged standing anteriorly and posteriorly against wall, cruise against wall, and better outdoor walking
F	III	sit with feet in front with a wider abduction, more straight legs, sustain prone sleeping, rolling, creep, prolonged standing anteriorly and posteriorly against wall, cruise against wall, and better outdoor walking
G	III	sit with feet in front with a wider abduction, flex one leg at hip and knee toward his chest from sitting with feet in front, sit with crossed legs, more straight legs, decrease toe standing, on the floor: attain sitting on the wheel chair and vice versa, crawl reciprocally forward instead of hitching, try to stand from floor, get up from the wall and try to take away from wall then try to stand free, desire and repetitive trying to stand up from the floor, prolonged standing anteriorly and posteriorly against wall, better outdoor walking
H	III	sit with feet in front with a wider abduction, decrease toe standing, better outdoor walking
I	IV	sustain prone sleeping, rolling, creep, sustain own weight on legs on a bench,

		better outdoor walking
J	IV	sit with feet in front with a wider abduction, , flex one leg at hip and knee toward his chest from sitting with feet in front, more straight legs
K	III	more straight legs, crawl reciprocally forward instead of hitching, kneeling walk, desire to stand by get up from the chair and try to take away from chair then try to stand, desire and repetitive trying to stand up from the floor, prolonged standing anteriorly and posteriorly against wall, cruise against wall, and better outdoor walking
L	IV	sit with feet in front, decrease toe standing, decrease deformity of external rotation toward neutral position, sustain prone sleeping, rolling, creep, sustain own weight on legs on bench
M	IV	sit with feet in front with a wider abduction, more straight legs, decrease toe standing, decrease deformity of external rotation toward neutral position, sit with arm free on high a bench
N	IV	sit with feet in front with a wider abduction, more straight legs, decrease toe standing, sit with arm free on high bench, hitching, sustain own weight on legs on a bench
O	III	more straight legs, stand on high bench with support

Appendix (8)

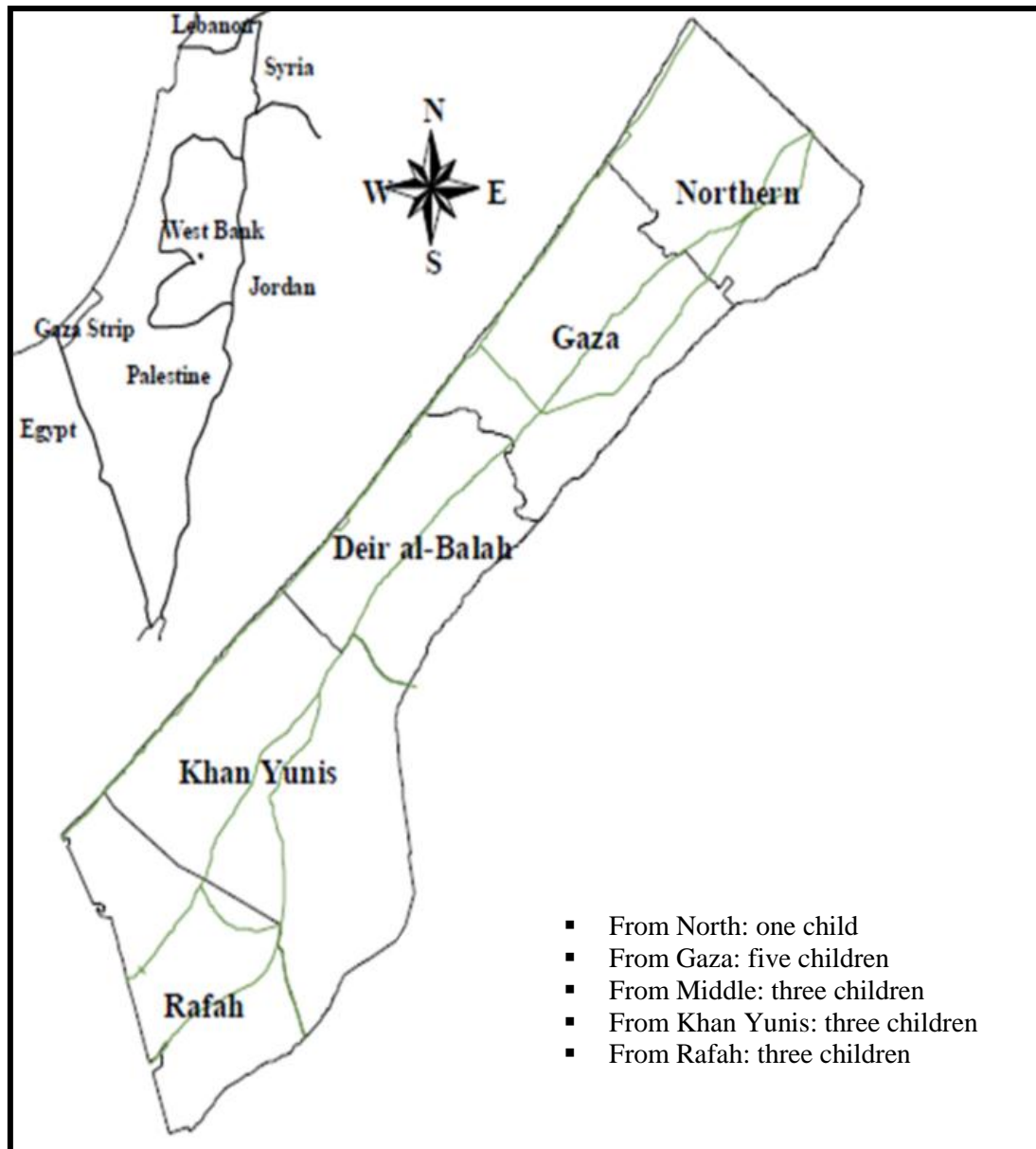

Figure 12: distribution of the study sample according to area.